

TCN 68-223: 2004

**PHS TERMINAL EQUIPMENT
Technical Requirements**

Contents

1. Scope	5
2. Normative references	5
3. Definition and abbreviations	6
3.1. Definitions	6
3.2. Abbreviations	7
4. Technical requirements	8
4.1. General requirements	8
4.1.1. Radio frequency band	8
4.1.2. Carrier frequency spacing	8
4.1.3. Communications system	8
4.1.4. Number of multiplexed circuits	8
4.1.5. Modulation method	8
4.1.6. Transmission rate	8
4.1.7. Voice coding rate	8
4.1.8. Frame length	8
4.1.9. Physical slot transmission condition	9
4.1.10. Transmission timing and transmission jitter	10
4.2. Conditions relating to transmitter and receiver	11
4.2.1. Frequency bands carrier numbers	11
4.2.2. Transmission characteristics	12
4.2.2.1. Transmission power	12
4.2.2.2. Transmission of calling identification code	12
4.2.2.3. Adjacent channel power	13
4.2.2.4. Transient response characteristics of burst transmission	13
4.2.2.5. Carrier off time leakage power	15
4.2.2.6. Transmission spurious	15
4.2.2.7. Allowed value for occupied bandwidth	16
4.2.2.8. Frequency stability	16
4.2.2.9. Modulation accuracy	16
4.2.2.10. Transmission rate accuracy	16
4.2.2.11. Cabinet radiation	17
4.2.3. Reception characteristics	17

4.2.3.1. Sensitivity.....	17
4.2.3.2. Adjacent channel selectivity	17
4.2.3.3. Intermodulation performance	17
4.2.3.4. Spurious response immunity	17
4.2.3.5. Conducted spurious component.....	18
4.2.3.6. Cabinet radiation.....	18
4.2.3.7. Receive signal strength indicator accuracy	18
4.2.3.8. Bit error rate floor performance	19
4.3. Antennas	19
5. Measurement methods	19
5.1. Testing the technical requirements.....	20
5.1.1. Transmission systems	20
5.1.1.1. Frequency error.....	20
5.1.1.2. Spurious emission	21
5.1.1.3. Occupied bandwidth	22
5.1.1.4. Antenna power	23
5.1.1.5. Carrier off time leakage power	24
5.1.1.6. Transient response characteristics of burst transmission.....	25
5.1.1.7. Modulation accuracy	25
5.1.1.8. Adjacent channel leakage power	27
5.1.1.9. Cabinet radiation.....	28
5.1.1.10. Signal transmission rate (clock frequency error).....	30
5.1.1.11. Transmission timing	30
5.1.2. Reception system.....	32
5.1.2.1. Sensitivity.....	33
5.1.2.2. Adjacent channel selectivity	33
5.1.2.3. Intermodulation characteristics	34
5.1.2.4. Spurious response immunity	35
5.1.2.5. Conducted spurious component:.....	35
5.1.2.6. Cabinet radiation.....	36
5.1.2.7. Carrier sensing (slot transmission conditions).....	36
5.1.2.8. Received signal strength indicator accuracy	37
5.1.2.9. Bit error rate floor characteristics	39

5.2. Measurement methods in case of no measurement terminal	39
5.2.1. Transmission system.....	39
5.2.1.1. Frequency error.....	39
5.2.1.2. Spurious emission	40
5.2.1.3. Occupied bandwidth	41
5.2.1.4. Antenna power	41
5.2.1.5. Carrier off time leakage power	41
5.2.1.6. Transient response characteristics of burst transmission.....	41
5.2.1.7. Modulation accuracy	41
5.2.1.8. Adjacent channel leakage power	41
5.2.1.9. Cabinet radiation.....	41
5.2.1.10. Signal transmission rate	41
5.2.1.11. Transmission timing	42
5.2.2 Reception system.....	42
5.2.2.1. Sensitivity (test site measurement)	42
5.2.2.2. Sensitivity (RFCD measurement).....	43
5.2.2.3. Adjacent channel selectivity	44
5.2.2.4. Intermodulation performance	44
5.2.2.5. Spurious response immunity.....	44
5.2.2.6. Conducted spurious components	45
5.2.2.7. Cabinet radiation.....	45
5.2.2.8. Carrier sensing (slot transmission conditions).....	45
5.2.2.9. Received signal strength indicator accuracy	45
5.2.2.10. Bit error rate floor characteristics (test site measurement)....	46
5.2.2.11. Bit error rate floor characteristics (RFCD measurement).....	46
5.3. Method for Other test items.....	47
5.3.1. Transmission of Calling Identification Code.....	47
5.3.2. Test for the Control Channel.....	48
ANNEX	50
ANNEX A (normative): Test Conditions.....	50
ANNEX B (informative): SIGNALLING AND COMMUNICATION CONTROL METHODS IN PHS SYSTEM.....	52
B.1. Layer 1	52

B.2. Link channel establishment phase	53
B.3. Service channel establishment phase and Communications phase	54
B.3.1. Layer 2 standards	54
B.3.2. Layer 3 standards	55
B.3.2.1. General	55
B.3.2.2. Radio frequency transmission management (RT).....	56
B.3.2.3. Mobility management (MM).....	58
B.3.2.4. Call control (CC)	59
B.3.2.5. Control sequences- Layer 3 standards.....	61
ANNEX C (informative): CONVERSION OF dBm INTO dB μ V	63
ANNEX D (informative): SAMPLE FORM OF.....	64
ASSESSING TEST REPORTS	64
D.1. Transmission system.....	64
D.2. Reception system.....	64
D.3. Other tests	65
ANNEX E (informative): SAMPLE FORM OF ASSESSING TECHNICAL DOCUMENTS OR TEST REPORTS	66
E.1. Signalling and call control	66
E.2. Other requirements.....	66

FOREWORD

The technical standard TCN 68-223: 2004 “**PHS Terminal Equipment – Technical Requirements**” is compiled according to the standard ARIB RCR STD-28 of Association of Radio Industries and Business of Japan and the related standards of other countries in the East Asia area.

The technical standard TCN 68-223: 2004 is drafted by the Posts and Telematics Quality Control Directorate at proposal of the Department of Science & Technology and adopted by the Decision No. 33/2004/QD-BBCVT dated 29/07/2004 of the Minister of Posts and Telematics.

The technical standard TCN 68-223: 2004 is issued in a bilingual document (Vietnamese version and English version). In cases of interpretation disputes, Vietnamese version is applied.

DEPARTMENT OF SCIENCE & TECHNOLOGY

PHS Terminal Equipment

Technical Requirements

(Issued together with the Decision No. 33/2004/QD-BBCVT dated 29/07/2004 of the Minister of Posts and Telematics)

1. Scope

This technical standard specifies the minimum technical requirements to be provided by Terminal Equipment in capable of connection to radio communication systems using PHS technology. These requirements apply to terminal equipment of the PHS System operating in the band of 1893.50 MHz ÷ 1919.600 MHz.

This technical standard covers the requirements to the radio interfaces and measurement method for type approval purpose of PHS Terminal Equipments.

This technical standard is used as the base of type approval for Terminal Equipments of PHS Systems operating in 1900 MHz band.

2. Normative references

- [1] ARIB RCR STD-28 Version 3.2 (02/12/1999): “Personal Handy Phone System - ARIB Standard”.
- [2] ARIB RCR TR-23 Version 3.2 (02/02/1999): “Personal Handy Phone System - Test items and conditions for public personal station compatibility confirmation”.
- [3] HKTA 1027 Issue 2 - February 2003: "Performance specification for Handy phone system (PHS) equipment for private use".
- [4] IDA TS PHS Version 2 - Issue 1 Rev 3, June 2001:"Type Approval specification for PHS Equipment Version 2 For use within the confined area of a building".
- [5] ACA Technical Standard TS 034 – 1997 “Radio Equipment and Systems Cordless Telecommunications - Personal Handy Phone System (PHS)".
- [6] “1900 MHz Digital Low Tier PHS Radio Terminal Equipment Technical Specifications” (23/07/2001) - Directorate General of Telecommunications, Ministry of Transportation and Communications, Taiwan.

3. Definition and abbreviations

3.1. Definitions

Antenna measurement terminal: It is a device created so that it operates with the same impedance when connected to the measurement equipment and when connected to the antenna.

Burst: A period of modulated carrier less than one timeslot. The physical content of a time slot. One burst in this description is 1 slot 0.625 ms in the personal handy phone system.

Call control (CC): This is the layer 3 entity that performs call service control.

Frame: This is a signal interval made up of 8 TDMA - TDD slots.

Guard time: This is the no-signal time used between bursts so that the transmission bursts do not collide with each other in adjacent slot intervals.

IA5 character: Coding recommended by ITU - T for putting characters / numbers into a signal and sending.

Message type: This is the information element used to identify the function of the message that is being transmitted.

Mobility management (MM): This is the layer 3 entity that performs the location registration and authentication function.

Radio frequency transmission management (RT): This layer 3 entity controls radio channel set up, holding, switching, etc.

Ramp time: This is a required transient response time for burst signal transmission.

Relative slot number: This is the relative slot position of the radio channel.

Scramble: This is the randomization of the transmission code series by taking the exclusive logical sum of the M series (Maximum period sequence: Largest period series) and the code series that should be transmitted. The scramble patterns are the same PN (10,3) for both PS transmission and CS transmission.

Slot: This is one signal interval of which 8 are provided in a 5 ms frame. They have a length of 0.625 ms, and there are two varieties: Individual assignment slots and common use slots.

Symbol: This corresponds to the 2 bits (5.2 μ s) radio interface transmission signal.

Synchronization burst: This is the signal transmitted for establishing synchronicity when switching channels and when setting up communication physical slots. It includes a 32 - bit unique word.

VOX control (Voice Operated Transmission): This is the function in which the communicating personal station turns transmission output ON/OFF according to the presence or absence of speech. This reduces personal station power consumption.

3.2. Abbreviations

ADAPCM	Adaptive Differential Pulse Code Modulation
ARIB	Association of Radio Industries and Businesses
CC	Call Control
CS	An abbreviation of Cell Station. It is the cell station.
CS-ID	CS Identification
FCS	Frame Check Sequence
FER	Frame Error Rate
FFT	Fast Fourier Transform
LCCH	Logical Control Channel
PHS	Personal handyphone system
PN	Pseudo-Noise
PS	Personal Station. Also called personal station or sub - device
PS-ID	PS Identification
R	Ramp (time)
RA	Rate Adaption
RCR	Research & Development Center for Radio Systems
RFCD	Radio Frequency Coupling Device
RLR	Receive Loudness Rating
SLR	Send Loudness Rating
STMR	Sidetone Masking rating
TA	Terminal Adapter
TCH	Traffic Channel
TE	Terminal Equipment
UW	Unique Word

4. Technical requirements

TE must satisfy all technical requirements below.

4.1. General requirements

4.1.1. Radio frequency band

The radio frequency band used is the 1,900 MHz band (1893.50 MHz ÷ 1919.600 MHz).

4.1.2. Carrier frequency spacing

The carrier frequency spacing is 300 kHz.

The carrier frequency is 1895.150 MHz or 1895.150 MHz + n x 300 kHz.

4.1.3. Communications system

It is a multiplex system that uses the multicarrier TDMA-TDD method.

4.1.4. Number of multiplexed circuits

The number of multiplexed circuits for TDMA is 4 (when using full rate codec). Also, with the exception of during channel switching, the maximum number of channels that can be simultaneously by a personal station is four.

4.1.5. Modulation method

The modulation method is $\pi/4$ shift QPSK modulation (quaternary phase modulation which has been shifted by $\pi/4$ each symbol period).

Transmission side filtering is Square Root of Raised Cosine with Roll-off factor (α) of 0.5.

4.1.6. Transmission rate

The signal transmission rate is 384 kbit/s.

4.1.7. Voice coding rate

The voice coding rate is 32 kbit/s-ADPCM (when applying full rate CODEC).

4.1.8. Frame length

The frame length is 5 msec (structure of 4 transmission slots + 4 reception slots).

4.1.9. Physical slot transmission condition

In the communications carrier, the appropriate corresponding slots are transmitted and used only after sensing the carrier within 2 seconds after transmission and confirming that the appropriate slot interval (called interval of 1 slot length) which can be used is idle across 4 or more frames. In the case where the preceding burst and continuing burst exceed the prescribed interference level, and they are present within or including the timing shown in Figures 4.1 and they overlap the slot scheduled for use, or the existing burst overlaps with the same timing as the slot scheduled for use, it is judged that.

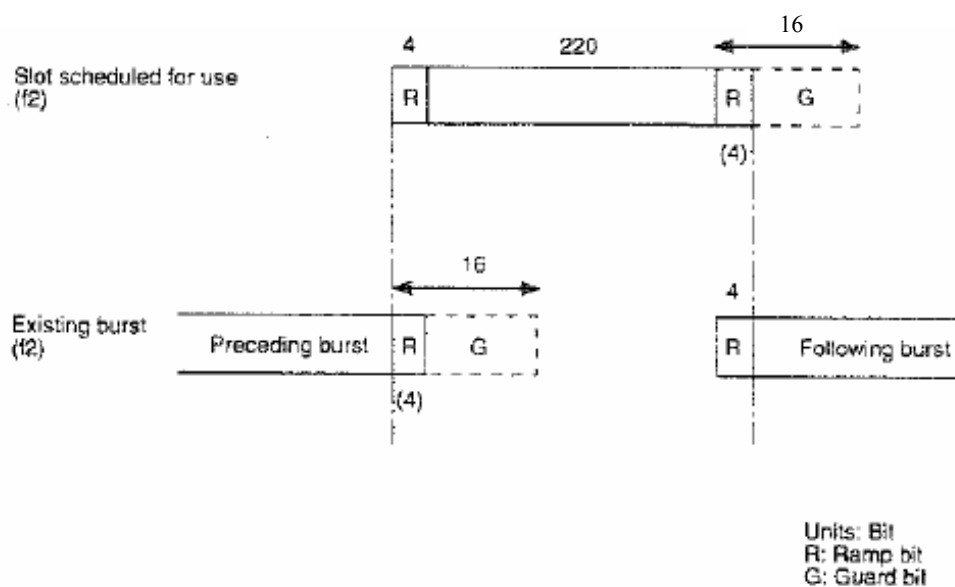

Figure 4.1: Carrier sensing method in PS side

In this case when the relevant channel's (called the relevant slot on the relevant carrier) interference level is above level 1; it is decided that the relevant channel is not available. However, only when the interference level of all channels used by the relevant radio station exceed level 1 (when there is a channels designation from the opposite station, called the relevant specified channel), it is decided that channels at interference level 2 or less can be used. Therefore, only in this case, it can be judged that channels whose interference level is level 2 or less are available free. However, slots already used by the relevant radio station are not objects of available slot determination.

Carrier sensing determination levels are as shown in Table 4.1.

Table 4.1. Carrier sensing levels

Level 1	26 dB μ V
Level 2	44 dB μ V

4.1.10. Transmission timing and transmission jitter

(1) PS timing

a) Definition

At the antenna terminal, standard timing of the control physical slot is taken as $(5 \times k_2 - 2.5)$ ms (k_2 is a natural number less than or equal to LCCH interval value) after the timing of the received control physical slot.

Also at the antenna terminal, standard transmission timing of the communication physical slot is taken as $(5 \times l - 2.5)$ ms (l is 1 when full rate, 2 when half rate, 4 when quarter rate) after the timing of the received communication physical slot. However, as for the relationship with the timing of the received designation physical slot (it is the transmission timing in PS between the last control or communication physical slot that contains a message that specifies the communication physical slot to CS (abbreviated as designation physical slot) and the relative communication physical slot at the antenna terminal), standard timing of the transmission timing of the relative communication physical slot is $(5 \times k_3 - 2.5 + 0.625 \times \{\text{absolute slot number of communication physical slot} - \text{absolute slot number of designation physical slot}\})$ ms (k_3 is a natural number) after the received designation physical slot.

b) Requirements

PS transmission timing, in the synchronized state, is within ± 1 symbol of the timing where interval accuracy of ± 5 ppm is added to standard timing.

Refer to Figure 4.2

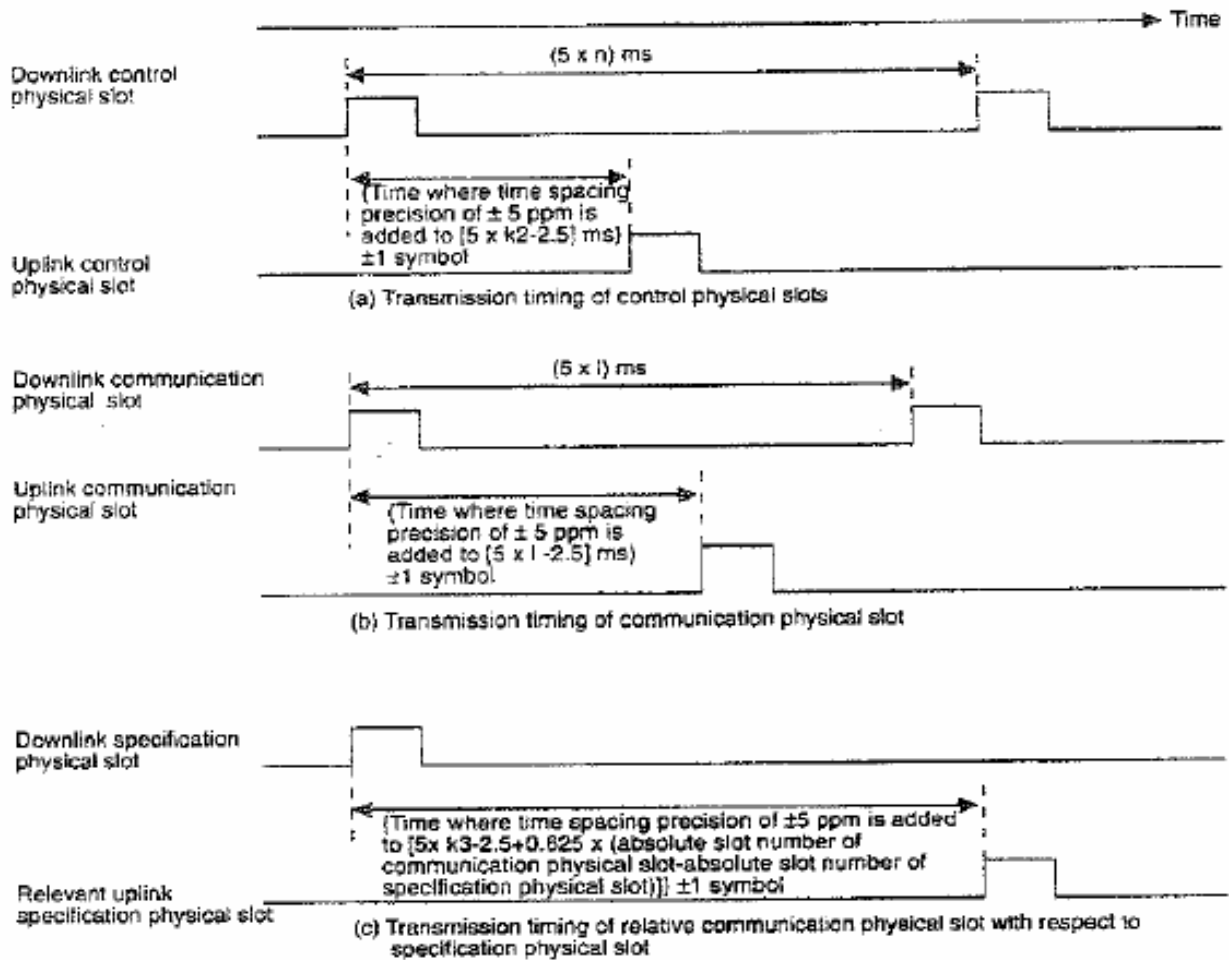

(Note) Figure (a), (b) and (c) show timing at the PS antenna terminal when wave propagation delay is not included.

Figure 4.2: PS transmission timing

(2) PS transmission jitter: PS transmission jitter is 1/8 symbol or less when PS is detecting 16-bit UW from CS. However, if CS has transmission jitter, it is the value minus the affected portion of CS transmission jitter.

4.2. Conditions relating to transmitter and receiver

4.2.1. Frequency bands and carrier numbers

Table 4.2. Relationship between frequency bands and carrier numbers

Carrier Numbers	Frequency bands (MHz)
251	1893.650
252	1893.950
253	1894.250
254	1894.550
255	1894.850

1	1895.150
2	1895.450
3	1895.750
4	1896.050
.	.
.	.
.	.
78	1918.250
79	1918.550
80	1918.850
81	1919.150
82	1919.450

Make sure that frequency used for control channels is the one of channel 1.

4.2.2. Transmission characteristics

4.2.2.1. Transmission power

(1) Definition

- a. If there is an antenna measurement terminal: It is antenna supplied power.
- b. If there isn't an antenna measurement terminal: It is antenna emission power measured at the test site or at the RFCD (Radio - Frequency Coupling Device) calibrated at the test site.

(2) Standards

Maximum transmission power: it is 10mW.

Output accuracy: Within + 20%, - 50%.

4.2.2.2. Transmission of calling identification code

When the calling identification code is transmitted, the signal transmitted from the transmitter must be follows:

- (1) For the personal stations, the signal is 28 bits, and for the digital cordless telephone base stations, the signal comprises 29 bits (Refer to ARIB RCR STD-28 section 4.2.10);
- (2) The signal has the established slot configuration, and transmits using channel coding and scrambling methods.

4.2.2.3. Adjacent channel power

(1) Definition

Adjacent channel power is average power in a burst radiated within a band of ± 96 kHz centering on a frequency separated by Δf kHz from the carrier wave frequency, in cases where it is modulated by a standard encoding test signal of the same coding speed as the modulated signal.

(2) Standards

- a. 600 kHz detuned: 800 nW or less.
- b. 900 kHz detuned: 250 nW or less.

4.2.2.4. Transient response characteristics of burst transmission

(1) Definition

When burst waves modulated by the digital signal at the radio station are ON/OFF, the burst transmission transient response characteristics is the time which is from the starting point of the transient response accompanying the turning off of the burst waves (refer Figure 4.4) until 80 nW is reached, or from 80 nW until the point at the end of the transient response accompanying turning on of the burst waves (refer Figure (4.4)).

(2) Standards

- a. Time characteristics: The time characteristics standards are 13.0 μ s or less. Also the instantaneous Power is in the range of the template shown in Figure 4.3.
- b. The power when off satisfies section 4.2.2.5.

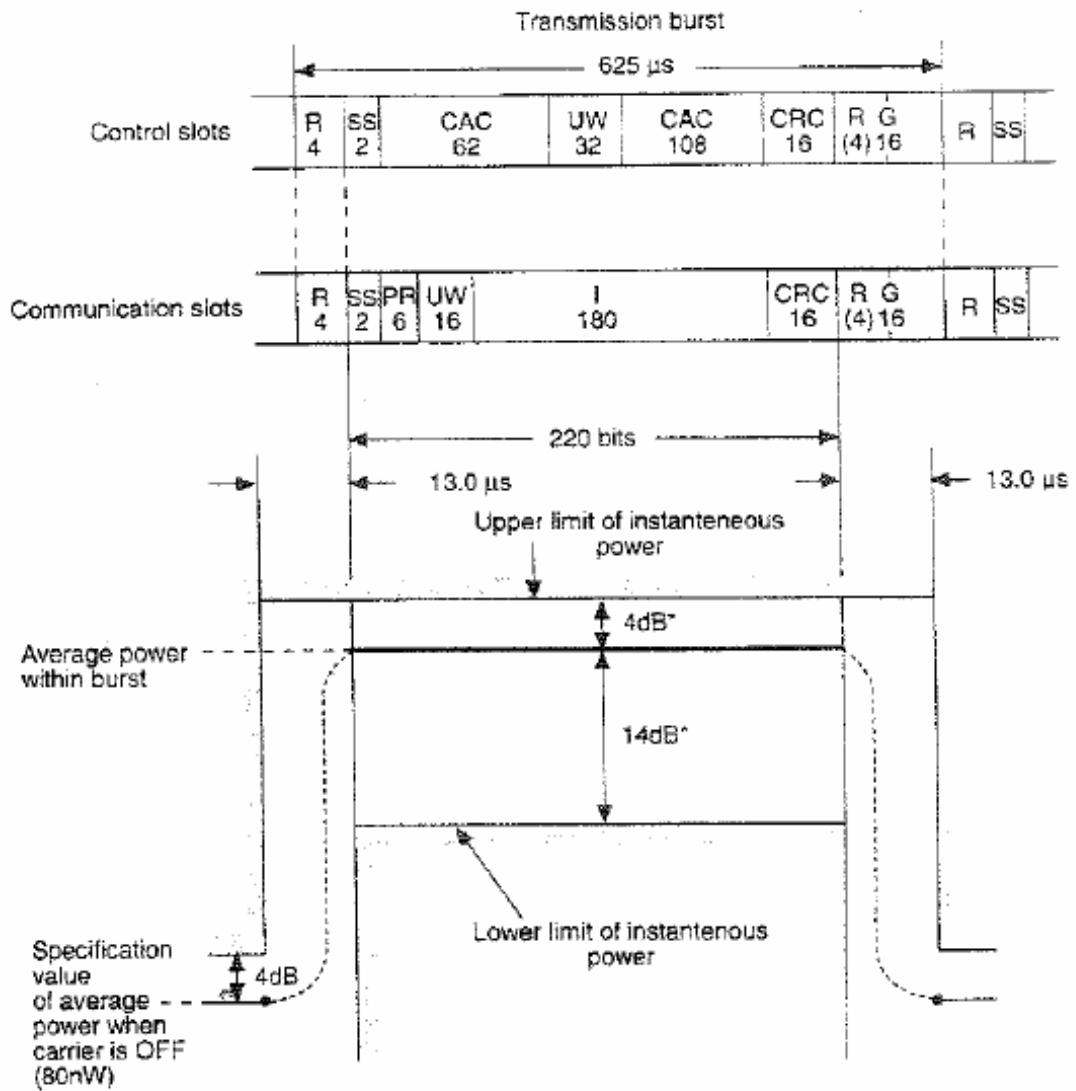

- * The upper and lower limits of instantaneous power are the ratio of the max power and min power with respect to average power of $\pi/4$ QPSK (root roll off $\alpha = 0.5$) (+2.9 dB and -11 dB) plus margins (max +1.1 dB, min -3 dB).

Figure 4.3: Standards of transmission power time response

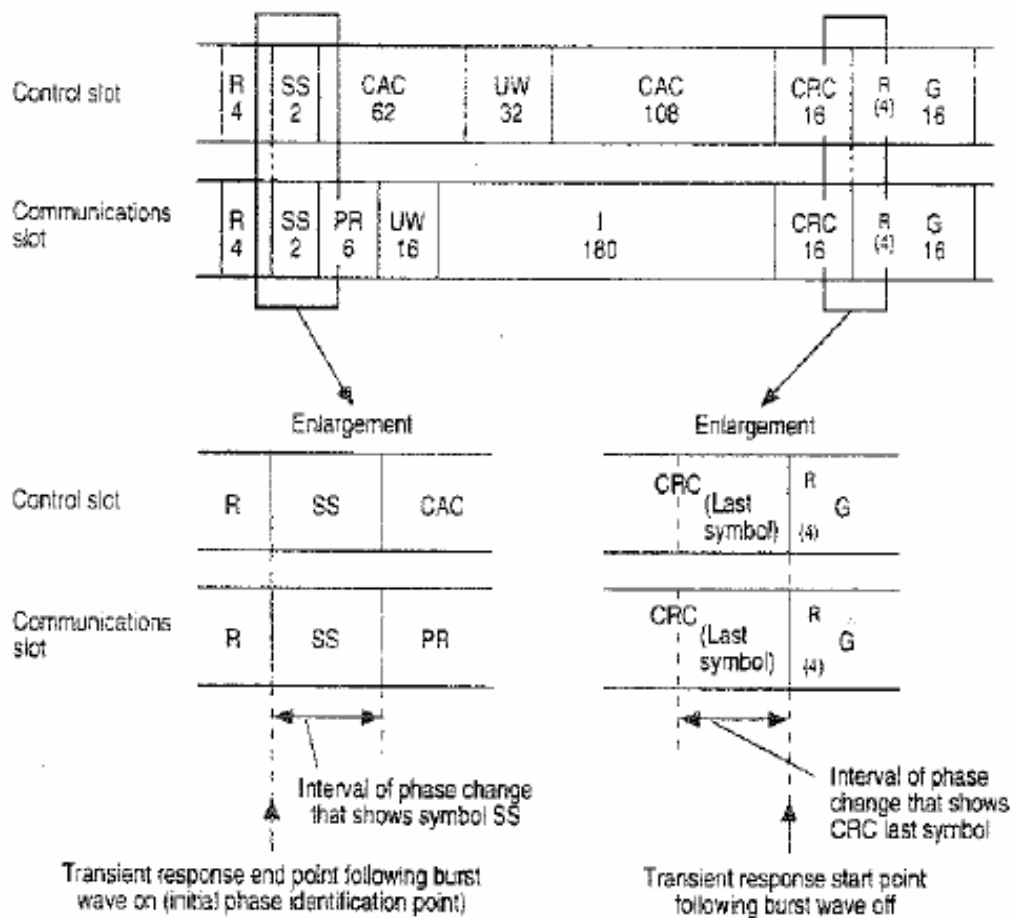

Figure 4.4 : Relationship between slot structure and burst wave on/off control

4.2.2.5. Carrier off time leakage power

(1) Definition

Carrier off time leakage power is power radiated in the relevant transmission frequency band within the no - signal time.

(2) Standards

It is 80 nW or less.

(3) The measurement is performed during communication, and the measurement period is the non transmission slot.

4.2.2.6. Transmission spurious

(1) Definition

Transmission Spurious is the average power of spurious emission (it is radiation of radio waves at 1 or more frequencies outside the required frequency band, and at a level which can be reduced without affecting information transmission. It

includes harmonic emissions, subharmonic emissions, parasitic emissions and intermodulation products, and does not include those generated in the course of modulation for information transmission by power emission at frequencies near the required frequencies near the required frequency band) for each frequency supplied to the power line.

(2) Standards

a. Within band 1,893.5 MHz ~ 1,919.6 MHz): 250 nW or less.

b. Outside of band (except above): 2.5 μ W or less.

(3) Measurement is performed during communication, and the measurement period is transmission slots and non - transmission slots (except within the band).

4.2.2.7. Allowed value for occupied bandwidth

(1) Definition

The occupied bandwidth is the frequency range that contains 99% of the Transmission Power, with 0.5% of the Transmission Power above this range, and 0.5% below this range.

(2) Standards

The allowed value is 288 kHz.

4.2.2.8. Frequency stability

(1) Definition

The frequency stability is the largest deviation that can be accepted from the assigned frequency of the frequency of the occupied bandwidth due to emissions.

(2) Standards

Absolute accuracy: $\pm 3 \times 10^{-6}$ or less.

4.2.2.9. Modulation accuracy

It is the actual value of the error of the signal point vector (the square root of the result of dividing the sum of the squares of the errors of the signal point vectors by the number of phase identification points within the slot) .

(2) Standards

It is 12.5% or less.

4.2.2.10. Transmission rate accuracy

The absolute accuracy of the personal station and cell station is 5×10^{-6} or less.

4.2.2.11. Cabinet radiation

Standards

It is 2.5 μW or less.

4.2.3. Reception characteristics

4.2.3.1. Sensitivity

(1) Definition

Sensitivity is the reception input level where the bit error rate (BER) becomes 1×10^{-2} when transmitting 2556 bits or more of a signal modulated by a 511-bit-period binary pseudo-noise series signal on TCH.

(2) Standards

It is 16 dB μV or less.

4.2.3.2. Adjacent channel selectivity

(1) Definition

Adjacent channel selectivity is the ratio of (specified sensitivity +3dB) to (the unwanted wave level at which the TCH BER becomes 1×10^{-2} due to unwanted signals added to the wanted signal of specified sensitivity +3dB (detuned by Δf kHz) modulated by a digital signal (binary pseudo-noise series with code length 32,767 bits)).

(2) Standards

It is 50 dB or more when detuned 600 kHz.

4.2.3.3. Intermodulation performance

(1) Definition

Intermodulation characteristics are the ratio of (specified sensitivity +3 dB) and the unwanted signal level at which the TCH bit error rate (BER) becomes 1×10^{-2} due to 2 unwanted signals added to the wanted signal of specified sensitivity (16 dB μV) + 3dB and detuned by 600 kHz and 1.2 MHz.

(2) Standards

It is 47 dB or more.

4.2.3.4. Spurious response immunity

(1) Definition

Spurious response immunity is the ratio of (specified sensitivity (16 dB μ V) +3dB) and the unwanted signal level at which the TCH bit error rate (BER) becomes 1×10^{-2} due to unmodulated unwanted signals added to the wanted signal of specified sensitivity (16 dB μ V) +3 dB.

(2) Standards

It is 47 dB or more.

4.2.3.5. Conducted spurious component

(1) Definition

It is the intensity of radio waves generated from the antenna terminal under reception conditions.

(2) Standards

It is 4 nW or less.

(3) Measurement is performed during standBy, and the measurement period is the entire interval.

4.2.3.6. Cabinet radiation

Below 1 GHz it is 4 nW or less; and above 1 GHz it is 20 nW or less.

4.2.3.7. Receive signal strength indicator accuracy

The reception level detection values (RF level predicted values) for RF input level of 16 dB μ V ÷ 60 dB μ V (dynamic range = 44 dB) have monotonically increasing characteristics, and absolute accuracy is ± 6 dB.

The reception level detection range (RF input level 10 dB μ V ÷ 80 dB μ V) and the permitted range of RF level predicted values for that are shown in Figure 4.5.

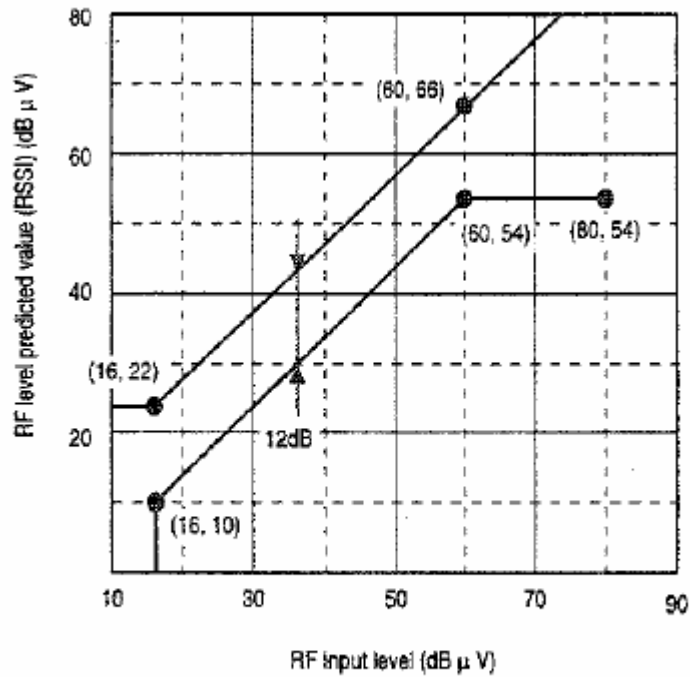

Figure 4.5: RF input level indicator accuracy

4.2.3.8. Bit error rate floor performance

(1) Definition

It is the input level which results in a bit error rate (BER) of 1×10^{-5} when a signal modulated by a 511-bit period binary pseudo-noiseseries signal is transmitted by TCH.

(2) Standard: 25 dBμV or less.

4.3. Antennas

Cabinet-built-in-type antenna with gain of 4 dBi or less. However, in cases where the effective radiated power is less than the value when the specified antenna power is applied to an antenna of absolute gain 4 dBi, the portion by which it is lower may be compensated by the gain of the antenna.

5. Measurement methods

It is mandatory to test the items list in part 4.1.9, 4.1.10 and 4.2 under normal test conditions, and also, where stated, under extreme test conditions specified in Annex A.

The terminal equipment should have guarantee documents which show its' conformity to the requirements in part 4.1, 4.3.

In this document, measurement methods for the case when there are antenna measurement terminals and data input/output terminals will be showed in 5.1 and 5.2. Measurement methods where there is no measurement terminals will be showed in 5.3.

The items common to each measurement method are as follows.

1. The standard coded test signal used in modulation is a binary pseudo-noise series of code length 511 bits, and travels on information channel I (TCH) or all slot intervals.
2. The definition of inside a burst period is at least 98 symbols from the first symbol immediately after rising until the last symbol immediately before falling.
3. The definition of outside a burst period is at least 720 symbols from the last symbol immediately before falling, excluding the last three symbols, to the first symbol immediately after the next slot rises, excluding the previous three symbols.

5.1. Testing the technical requirements

5.1.1. Transmission systems

5.1.1.1. Frequency error

a. Frequency error (frequency counter method)

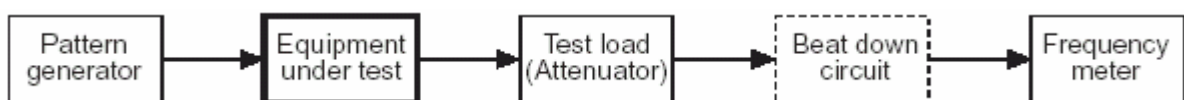

Figure 5.1.1.1a. Frequency error (frequency counter method)

Note

- Set at test frequency and transmit. Modulate with the standard coded test signal.
- In test mode measurement and so forth, in cases where special code modulation is possible in the traffic channel or all slot intervals, it can be measured and the offset portion can be corrected. (Reference: If there is zero continuation, Offset is 24 kHz.)
- In test mode measurement, in cases where unmodulated carrier can be output, it can be measured unmodulated in cases of circuit methods where the center of the modulation spectrum is the carrier frequency.
- In test mode setting, if continuous transmission is possible, measurement in that state is possible.

* Measurement procedures (Measure diagram is shown in Figure 5.1.1.1a)

Measure 100 individual bursts or more and find the average; that is the measured value. In the case of continuous transmission, measure with a gate time by which accuracy 1 order of magnitude can be obtained, better than the required accuracy.

* Other methods

Measurement of the reference oscillator output frequency can be substituted if the transmitter circuit construction is one in which the reference oscillator's frequency accuracy is the transmitter output frequency accuracy.

b) Frequency error (phase locus method)

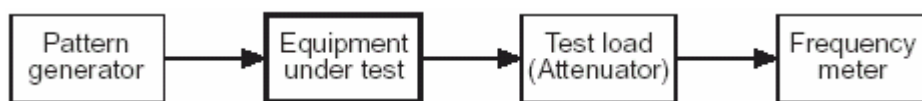

Figure 5.1.1.1b : Frequency error (phase locus method)

(Measure diagram is shown in Figure 5.1.1.1b), Measure output frequency of the equipment under test with the frequency meter.

5.1.1.2. Spurious emission

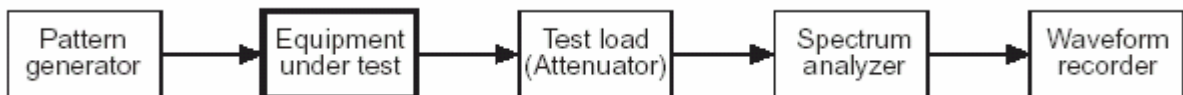

Figure 5.1.1.2. Spurious emission

* Measurement procedures (Measure diagram is shown in Figure 5.1.1.2)

- Detection of spurious emission: For the required band, sweep slowly and confirm spurious frequency. Frequency band to be detected is in a band from 100 kHz to 4 GHz detuned at least ± 1 MHz from the transmission frequency.

- Center frequency setting: The center frequency setting of the spectrum analyzer is aligned to the spurious frequency.

- Measurement: Make a single sweep in the time domain and measure power distribution. When the resolution bandwidth is varied and the level varies, convert to designated bandwidth (192 kHz) for adjacent channel leakage power.

- Data input: When the sweep is completed, the values of sample points inside and outside the burst period are entered into the array variable of the computer.
- Antilogarithm conversion: The dBm value of the input data is converted to the antilogarithm of the power dimension.
- Power average: The converted antilogarithm data is averaged within the burst period of the spurious emission, and the average power is found. The sample spacing is the reciprocal of the signal transmission rate or less.

Note: For the spectrum analyzer, sweep time is about 1 msec (one or more bursts per sample, for examples if there are 1001 points, 5 seconds or more). Sample detection mode is positive peak.

5.1.1.3. Occupied bandwidth

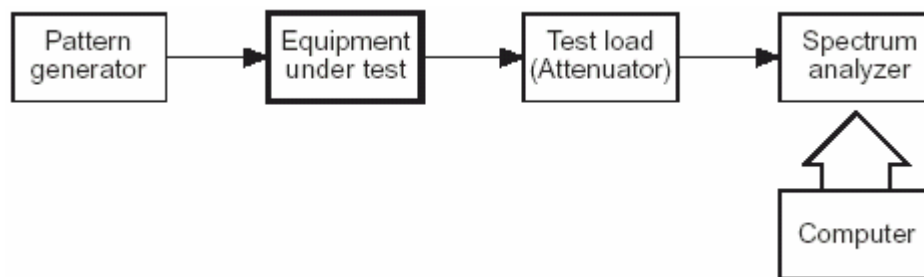

Figure 5.1.13 Measurement diagram of Occupied bandwidth

* Measurement procedures (Measure diagram is shown in Figure 5.1.1.3)

- Measurement: The spectrum analyzer does a single sweep and measures the spectrum distribution with more than or equal 400 sample points (for example 1001 sample points).
- Data input: When the sweep is completed, the values of all sample points are entered into the computer's array variable.
- Antilogarithm conversion: The dBm value for all data is converted to the antilogarithm (relative value may be used) of the power dimension
- Calculation of total power: The total power of the whole sample is found and recorded as "total power".
- Calculating lower frequency limit: Sequentially look up at the whole of sample points from the sample with the lowest frequency to find out the first sample point of which power is about 0.5% of "total power". That sample point is converted to a frequency and recorded as "lower frequency limit".
- Calculating upper frequency limit: Sequentially look up at the whole of sample points from the sample with the highest frequency to find out the first sample

point of which power is about 0.5% of "total power". That sample point is converted to a frequency and recorded as "upper frequency limit".

- Calculating occupied bandwidth: the occupied bandwidth is found as "upper frequency limit" - "lower frequency limit".

Note: For the spectrum analyzer, sweep time is one or more bursts per sample; if there are 1001 points, 5 seconds or more. Detection mode is positive peak.

5.1.1.4. Antenna power



Figure 5.1.1.4 a. Measurement diagram of antenna power (a)

a) Diagram 5.1.1.4.a

Use a power meter which has a time constant adequately longer than the burst and which displays the true root mean square value power. The power is measured by the power meter. When transmitting multiple slots, divide the displayed value by the number of transmission slots.

b) Diagram 5.1.1.4.b

- Measurement: The spectrum analyzer does a single sweep and measures the power distribution. Sweep time is about 1ms (for 1 slot transmission)
- Data input: When the sweep is completed, the values of the sample points within the burst period are entered into the computer's array variable.
- Antilogarithm conversion: The voltage value for the acquired data is converted to the antilogarithm of the power dimension.
- Power averaging: The antilogarithm converted data is averaged, and this is multiplied by (burst period : 0.583 ms^{*1})/(frame period : 5 ms).

The sample spacing is the reciprocal of the signal transmission rate or less.

Note: *1: The time of 0.583 ms is set as the time for each 110 symbol + the preceding symbol and subsequent symbol. For different designs, however, another value can be used.

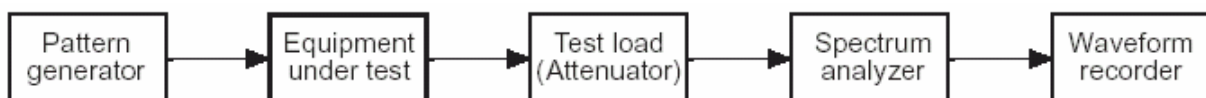

Figure 5.1.1.4 b: Measurement diagram antenna (b)

5.1.1.5. Carrier off time leakage power

The overall operating characteristics test equipment can output to the spectrum analyzer the gate signal corresponding to the burst period.

Measurement procedures (Measure diagram is shown in Figure 5.1.1.5)

- Detecting carrier off time leakage power: The spectrum analyzer gate function is used so that the output in the burst period does not appear; single sweep is done, and the indicated value is recorded for the carrier-off time leakage power.
- Transmitter power measurement: The gate function is disabled and the spectrum analyzer does a single sweep and measures the indication of the carrier power.
- Carrier-off time leakage power computation: The carrier-off time leakage power is computed from the difference between two indicated values above, based on the measured value of the antenna power.
- Average power within burst: If one feels that measurement accuracy up through computed carrier-off time leakage power above is insufficient due the fact that carrier-off time leakage power is burst-shaped, etc., measure the average power within the burst (Indicates the period of the of leakage power burst) with the spectrum analyzer set in the same way as in Section 5.1.1.2 Spurious emission. However, the period to be measured is outside of the transmission burst period.

Note: For the spectrum analyzer, sweep time is one or more bursts per sample; if there are 1001 points, 5 seconds or more. Detection mode is positive peak. Video gate: the gate timing is adjusted so that the output in the burst period does not appear.

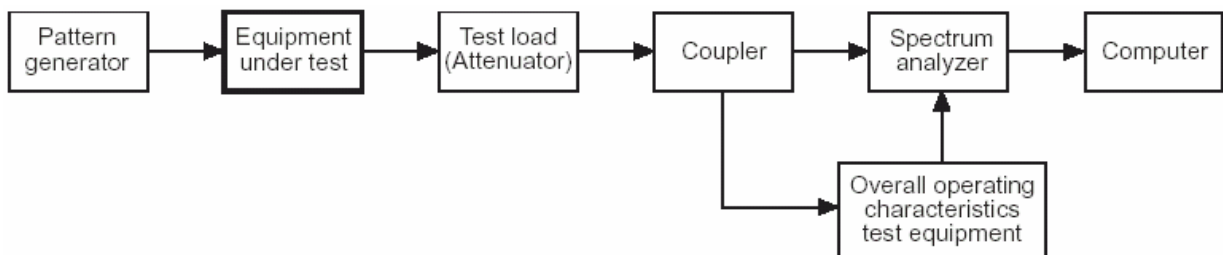

Figure 5.1.1.5: Measurement diagram of carrier offtime leakage power

5.1.1.6. Transient response characteristics of burst transmission

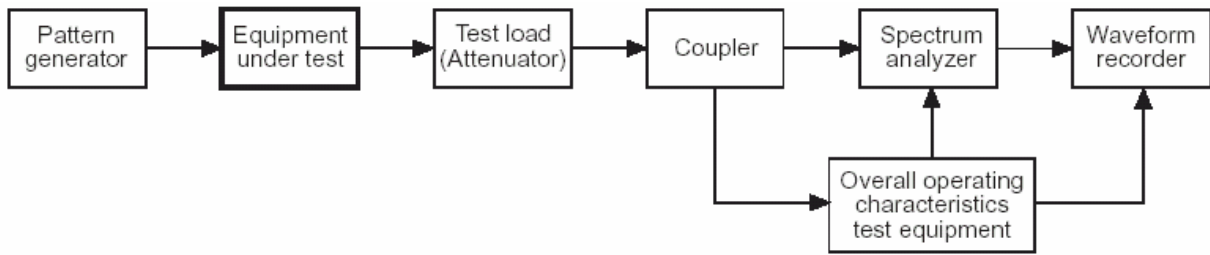

Figure 5.1.1.6 : Measurement diagram of transient characteristics of burst transmission

The video output signal is taken by the waveform recorder. Sweep trigger of the video output signal is external trigger that can be combined with delay sweep, and sweep time is about 30 μ s. The overall operating characteristics test equipment can output a trigger signal corresponding to the transmission burst timing.

Measurement procedures (Measurement diagram is shown in Figure 5.1.1.6): The spectrum analyzer video output signal is measured by the waveform recorder.

5.1.1.7. Modulation accuracy

a. Definition: If ideal transmitter output passes through an ideal root roll-off reception filter and is sampled at ideal points with one symbol spacing, since interference between codes does not occur, modulation sequence values can be defined by the following equation.

$$S(k) = S(k - 1) \exp[(\pi/4 + B(k)) * \pi/2]$$

Here, the following table shows $B(k) = 0, 1, 2, 3$.

X _k	Y _k	B(k)
0	0	0
0	1	1
1	1	2
1	0	3

X_k and Y_k indicate two pieces of data that have been converted by serial-parallel conversion from a binary data series. On the other hand for actual transmitted signals, interference between code occurs. The modulated accuracy is defined by measuring this error.

b. Modulation accuracy definition formula

When transmission is done with actual transmitters and passes through an ideal reception filter, if $Z(k)$ is the signal obtained at instant k with 1-symbol spacing, we can show the following using $S(k)$.

$$Z(k) = [C_0 + C_1 * \{S(k) + E(k)\}] * W^k;$$

Here, $W = e^{dr+jda}$: Amplitude change of dr [neper/symbol] and frequency offset that corresponds to phase rotation of da [rad/symbol];

C_0 : Fixed zero offset signifying imbalance in quaternary modulators;

C_1 : Complex constant signifying transmitter's optional phase and output power

$E(k)$: Residual vector error of sample $S(k)$.

The sum of the squares of the vector errors is the following equation.

$$\sum_{k=Min}^{Max} |E(k)|^2 = \sum_{k=Min}^{Max} \left| \frac{[Z(k)W^{-k} - C_0]}{C_1} - S(k) \right|^2$$

C_0 , C_1 , W are selected in order to make this equation smallest, and are used to compute the vector error in relation to each symbol. The symbol timing position of the reception output is also selected to minimize the vector error.

The channel (individual assignment) MAX and MIN can be given by:

MIN = 2 (vector immediately after ramp-up);

MAX = 112 (vector immediately before ramp-down).

The r.m.s. value for vector error is calculated as the square root of the result of dividing the sum of the second power of the vector error by the number of phase identification points in a slot (111).

The r.m.s. value of this vector error is defined as the modulation accuracy.

c. Measurement procedures (Measurement diagram is shown in Figure 5.1.1.7)



Figure 5.1.1.7. Measurement diagram of modulation accuracy

The modulation accuracy measurement equipment has a reception root roll-off filter function, and it can measure the r.m.s. difference between the transmitted signal and the ideal signal.

- Measure difference between actual transmission wave and ideal vector convergence point in signal space.

- Add the square of the vector errors for each point obtained in a. above; divide it by the number of phase identification points within a slot; find the square root of this.

5.1.1.8. Adjacent channel leakage power

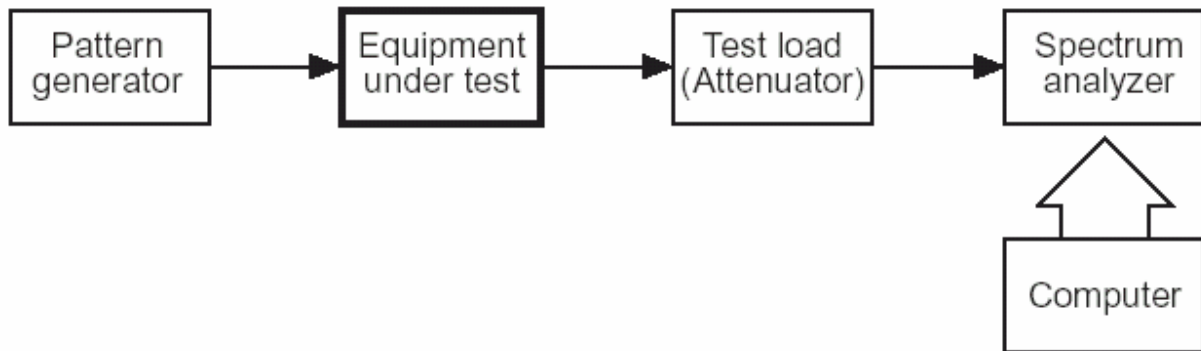

Figure 5.1.1.8: Measurement of Adjacent channel leakage power

Measurement procedures (Measurement diagram is shown in Figure 5.1.1.8)

- *Step 1:* Set the center frequency of the spectrum analyzer to the carrier frequency.
- *Step 2:* After sweeping is finished, enter all sample points into the array variable of the computer.
- *Step 3:* For all samples, convert the dBm value into the antilogarithm of the power dimension (relative value may be used).
- *Step 4:* Determine the power sum of all samples in specified bandwidth, and record total power (P_c).
- *Step 5:* Measurement of upper adjacent channel power (P_u)
Set the center frequency of the spectrum analyzer to the frequency set in *Step 1* + Δf kHz (specified detuned frequency), and repeat *Step 2* to *Step 4*. The sum is referred to as P_u .
- *Step 6:* Measurement of lower adjacent channel power (P_l): Set the center frequency of the spectrum analyzer to the frequency set in *Step 1* - Δf kHz (specified detuned frequency), and repeat *Step 2* to *Step 4*. The sum is referred to as P_l .
- *Step 7:* Presentation of results: Upper adjacent channel power ratio is $10 \log (P_c/P_u)$. Lower adjacent channel power ratio is $10 \log (P_c/P_l)$. Subtract the above calculated value - 9 dB from the measured value of antenna power (dBm), and

use this as the dBm measured value of each adjacent channel power. For measured values, these values can be converted to nW units.

- *Step 8:* For specification in which Δf varies, repeat *Step 5.* and *Step 6.* while varying Δf .

5.1.1.9. Cabinet radiation

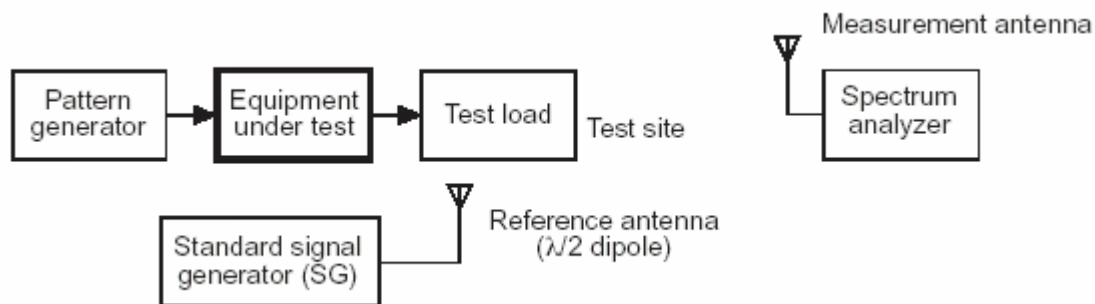

Figure 5.1.1.9: Measurement diagram for Cabinet radiation

Note

Measurement equipment conditions, etc.

- The equipment under test terminates the antenna terminal with a test load.
- Perform in a anechoic chamber with measurement distance 3 m or at an open area test site where ground-reflected waves are suppressed, and use a directional antenna for the measurement antenna. To suppress ground-reflected wave, install radio wave absorbers or a radio wave curtain on the ground at the measurement mid-point. The equipment under test should be set as high as possible.
- If one side of the equipment under test exceeds 60 cm, the measurement distance must be at least 5 times that. If the measurement frequency is less than 100 MHz, perform at an open area test site with measurement distance of 30 m.
- If using an RFCD: Radio-Frequency Coupling Device, calibrate coupling for each frequency measured, using the same model of the equipment, at the above mentioned test site.
- The reference antenna for replacement is a $\lambda/2$ dipole, and the measuring frequency range is 25 MHz ÷ 4 GHz.
- In the case where the detected radiation is burst-shaped, add conditions and procedures that conform to "spurious emission."

* Measurement procedures (Measurement diagram is shown in Figure 5.1.1.9)

- *Step 1:* Install the equipment under test on a turn table, and for the band of specified frequency, confirm the radiation of a spectrum.
- *Step 2:* Among those checked above, the spectrum analyzer is tuned to one frequency component.

- *Step 3*: The measurement antenna is vertically or horizontally polarized as inferred from the structure of the equipment under test.
- *Step 4*: The turn table is rotated, and set to the maximum indication angle of radiation (average power within burst period).
- *Step 5*: The measurement antenna is again raised and lowered, and set to the maximum indication.
- *Step 6*: The equipment is rotated on the vertical plane that contains the measurement antenna, and it is set at the angle of the maximum indication.
- *Step 7*: By varying the measurement antenna polarization, it is confirmed that it conforms to *Step 3*. If different, *Step 4*, *5* or *6* is repeated as needed at the polarity in the different directions, and the frequency, maximum indication, each angles and measurement antenna and polarity are recorded.
- *Step 8*: The *Steps 2–7* above are carried out for all the spectrum frequencies found in *Step 1*.
- *Step 9*: The equipment under test is replaced with the reference antenna.
- *Step 10*: The reference antenna is tuned as needed to the frequency of the spectrum measured in *Step 7* above.
- *Step 11*: The reference antenna and the measurement antenna are both polarized in the way when measured in *Step 7* above.
- *Step 12*: The measurement antenna is raised and lowered, and the output level of the SG is adjusted so that the largest maximum indication of the spectrum analyzer matches the maximum value above found in *Step 7*. The SG output level and the measurement antenna height at this time are both recorded.
- *Step 13*: *Steps 10 - 13* are repeated for all frequency components measured.
- *Step 14*: Exchange the measurement antenna as necessary, and repeat until measurement of 25 MHz – 4 GHz is finished.

* Presentation of results

The cabinet radiation is reference antenna gain and SG/reference antenna cable loss correction added to the SG output level found in the measurements in *Step 1* to *14*.

5.1.1.10. Signal transmission rate (clock frequency error)



Figure 5.1.1.10: Measurement diagram for signal transmission rate (clock frequency error)

* Measurement procedures (Measurement diagram is shown in Figure 5.1.1.10)

The clock frequency of the equipment under test is measured.

Calculate the error with respect to the nominal value of the measured value determined above.

Note:

- The frequency resolution of frequency meter should be smaller than one tenth of the transmission rate specification (clock frequency error). If the clock is a burst output, a frequency counter is used that can measure the burst clock frequency.
- The EUT should be set in a state where the direct communication between personal stations are possible or transmission test mode are possible.
- If a reference clock source of a frequency synthesizer that generates a transmission carrier is used as the transmission clock source, the error measured in section 5.1.1.1 can be used.
- If the clock output from the equipment under test is other than 384 kHz and the clock source is shared, the measured frequency error can be used.

5.1.1.11. Transmission timing

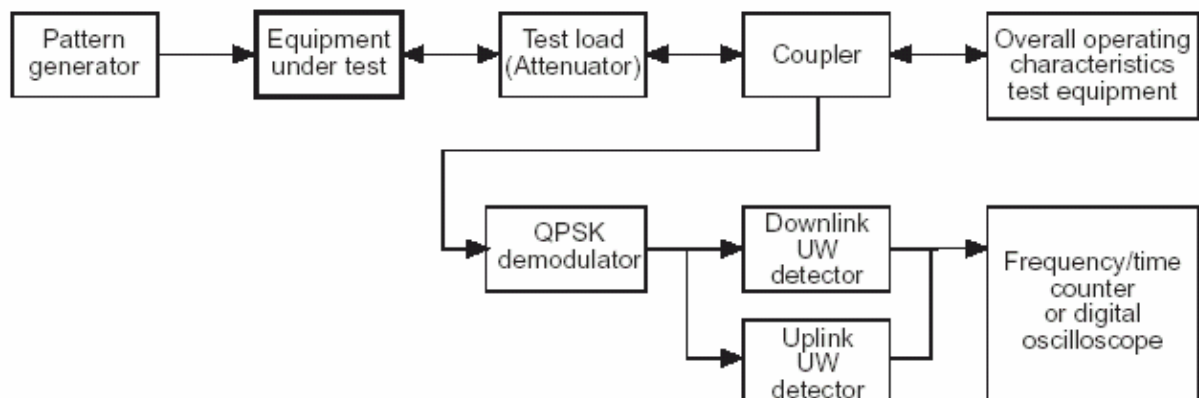

Figure 5.1.1.11a: Measurement system diagram for Transmission timing a

a) Measurement diagram 5.1.1.11.a

Note:

+ Measurement equipment conditions:

- The overall operating characteristics equipment performs control sequences such as call origination with the equipment under test (cell station or personal station).
- The QPSK demodulator can demodulate the specified burst signal.
- The uplink and downlink UW (unique word) detectors each have a clock synchronization circuit and UW detection circuit, and by narrowly dividing the timing detection, the required detection accuracy is obtained. If necessary, UW detection output of uplink or downlink only is possible.
- The digital oscilloscope can perform delay sweep, and its time axis resolution is sufficiently fine, and is calibrated by a high-stability oscillator.

+ Equipment under test is set to the test frequency, and transmit. It is in communication state with the overall operating characteristics test equipment.

* Measurement procedures:

- The downlink UW detector and uplink UW detector are operated, and the detected output pulse spacing is measured.
- It is measured multiple times, and the averaged value is taken as the transmission timing, and the jitter is the maximum deviation from this average.
- The measured values in time units are converted to number of symbols.

b) Measurement system diagram 5.1.1.11 b

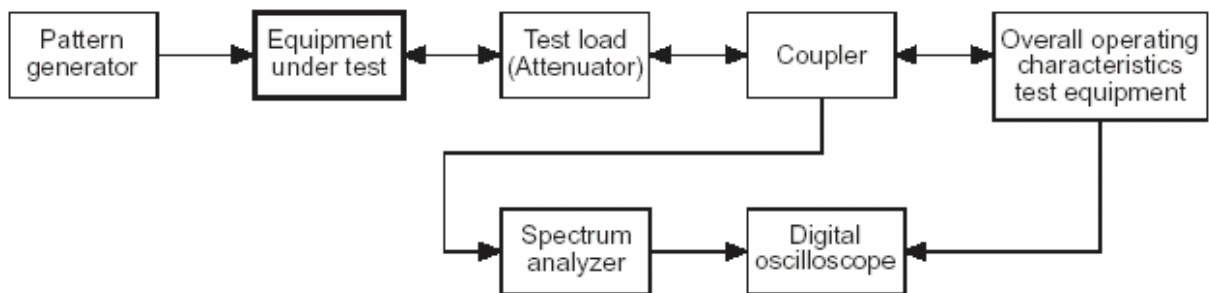

Figure 5.1.1.11b: Measurement system diagram b

* Measurement procedures

Using the delayed sweep of the digital oscilloscope, measure the spacing of the same point of the envelope line having a specific pattern. Measure several times, and take the averaged value as transmission timing. The jitter is the maximum deviation from the average value. The measured value of time units is converted to number of symbols.

Note: The output signal of overall operating characteristic test equipment is lower than that of the equipment under test, and the signal of equipment under test can easily be distinguished it's self on the screen of a digital oscilloscope. This equipment can also has trigger signal output that correspond to it's transmission timing.

5.1.2. Reception system

Here, facts common to the measurement items that accompany error rate measurement are described.

* Measurement system diagram (figure 5.1.2)

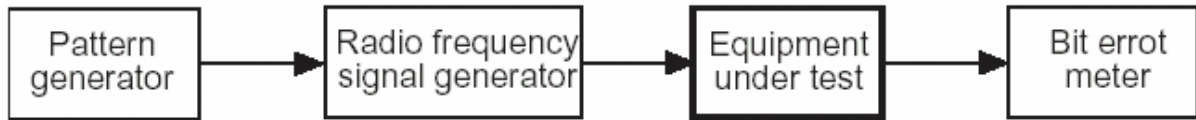

Figure 5.1.2: Measurement system diagram for error rate

* Measurement equipment conditions, etc.

- Radio-frequency signal generator
- + Frequency of the specified frequency band
- + Frequency accuracy: Within $\pm 1 \times 10^{-7}$
- + Modulation accuracy: Within r.m.s. vector error 3% (recommended value)
- + Adjacent channel leakage power:
 - ± 600 kHz detuned at least 80 dB below carrier power (recommended value)
 - ± 900 kHz detuned at least 80 dB below carrier power (recommended value)
- + Level calibration: In the state where a continuous carrier wave is modulated by repetition of a standard coded test signal, it is performed with a power meter. Output level of overall operating characteristics test equipment is the same.
- + Undesired signal timing: Transmitted at least across entire burst period of the desired signal.
 - Pattern generator:
- + Clock frequency: 384 kHz;
- + Clock frequency accuracy: Within $\pm 1 \times 10^{-6}$;
- + Generated pattern: The standard coded test signal that is transmitted by the information channel I (TCH) (binary pseudo-noise series of code length 511 bits conforming to ITU-T O.153) is generated continuously. Further, other patterns needed in communications to parts of the traffic channel other than the I (TCH) are generated.

* Measurement procedures:

- The radio-frequency signal generator repeatedly sends the communication physical slot burst following the pattern input from the pattern generator.

-The equipment under test is put into reception mode at the test communication frequency, and the information channel I (TCH) of the demodulated data is supplied to the bit error meter.

-The bit error meter accumulates bit sequence from the information channel I (TCH) and measures the error rate for 2556 bits or more.

5.1.2.1. Sensitivity

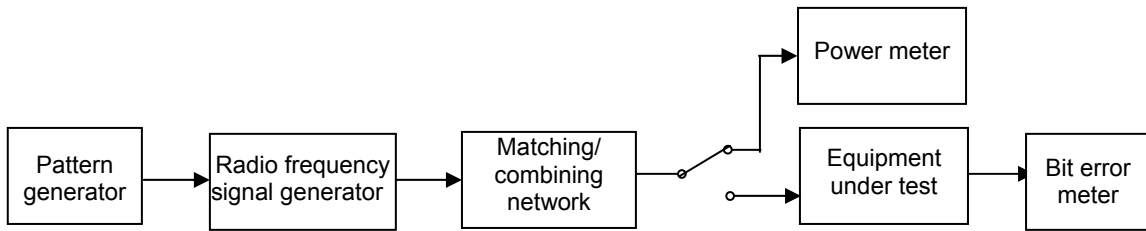

Fig 5.1.2.1 : Measurement system diagram for Sensitivity

Measurement procedures (Measurement diagram is shown in Figure 5.1.2.1)

- The radio frequency signal generator is to be tuned to the test frequency.
- The radio frequency signal generator transmits bursts. The signal level is set at the standard sensitivity level. And the switch is changed, signal is supplied to equipment under test.
- The bit error meter accumulates bit sequence from the information channel I (TCH) and measures the error rate for 2556 bits or more.

5.1.2.2. Adjacent channel selectivity

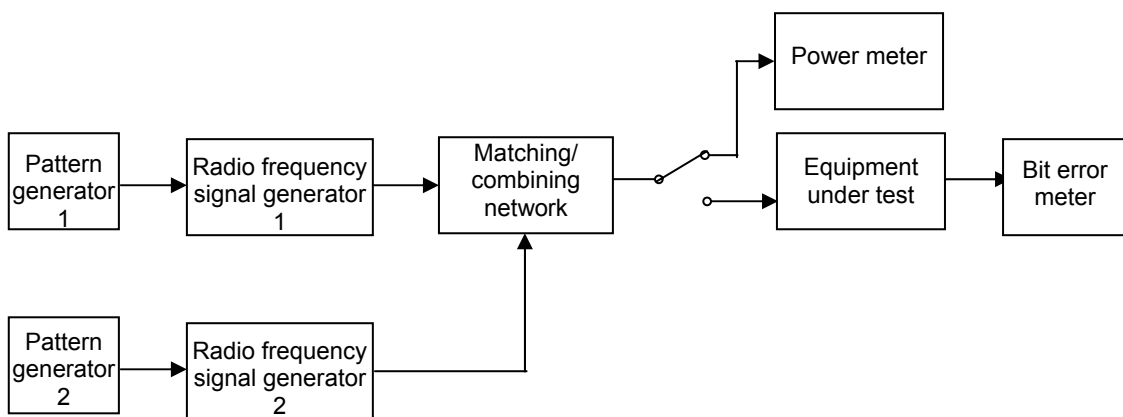

Figure 5.1.2.2: Measurement system diagram for Adjacent channel selectivity

- a. Measurement equipment conditions: Radio frequency signal generator and Pattern generator 1 is referred to Error rate measurement. Pattern generator 2: Clock frequency 384 kHz Clock frequency accuracy within $\pm 1 \times 10^{-6}$.

Generated pattern Digital signals (binary pseudo-noise series of code length 32,767 bits conforming to ITU-T O.151) are continuously generated.

b. Measurement procedures (Measurement diagram is shown in Figure 5.1.2.2)

- The radio frequency signal generator 1 is to be tuned to the test frequency.
- The radio frequency signal generator 2 is to be tuned to the frequency of the adjacent channel.
- Radio frequency signal generator 1 does burst transmission. The signal level is set to the value at which the specified sensitivity level + 3 dB is obtained.
- Radio frequency generator 2 does continuous or burst transmission. The signal level is set at the value which produces [(specified sensitivity level + 3 dB) + (adjacent channel selectivity specified value) dB] dB μ V.
- The bit error meter accumulates bit sequence from the information channel I (TCH) and measures the error rate for 2556 bits or more.

5.1.2.3. Intermodulation characteristics

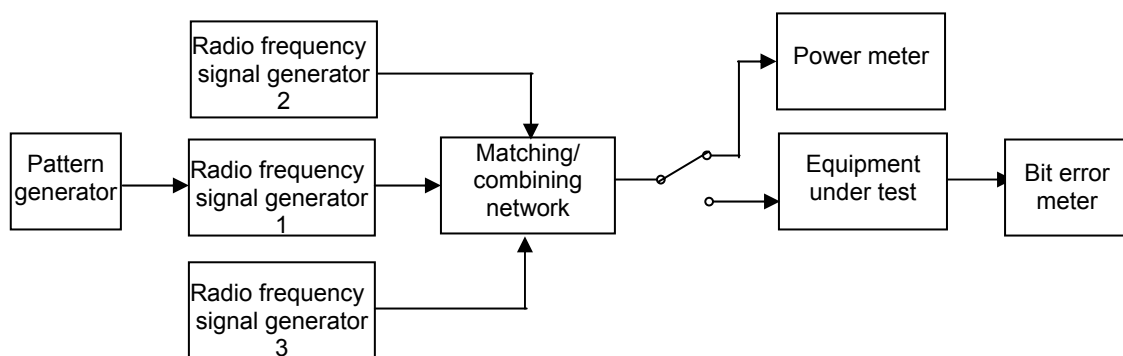

Figure 5.1.2.3 Measurement system diagram for Intermodulation characteristics

Measurement procedures (Measurement diagram is shown in Figure 5.1.2.3)

- The radio frequency signal generator 1 is to be tuned to the test frequency.
- The radio frequency signal generator 2 is to be tuned to test frequency ± 600 kHz and the radio frequency signal generator 3 is to be tuned to test frequency ± 1200 kHz.
- Radio frequency signal generator 1 does burst transmission. The signal level is set at the value which produces the specified sensitivity level + 3 dB.

- Radio frequency signal generators 2 and 3 do continuous or burst transmission, and are not modulated. The signal levels of radio frequency generators 2 and 3 are set at the value which produces $[(\text{specified sensitivity level} + 3 \text{ dB}) + (\text{intermodulation characteristics specified value})]$ dB μ V.
- And the switch is changed, signal is supplied to equipment under test.
- The bit error meter accumulates bit sequence from the information channel I (TCH) and measures the error rate for 2556 bits or more.

5.1.2.4. Spurious response immunity

Measurement procedures (Measurement diagram is shown in Figure 5.1.2.4)

- The radio frequency signal generator 1 is to be tuned to the test frequency.
- The radio frequency signal generator 2 is to be tuned to the spurious frequency.
- Radio frequency generator 1 does burst transmission. The signal level is set at the value which produces the specified sensitivity level + 3 dB.

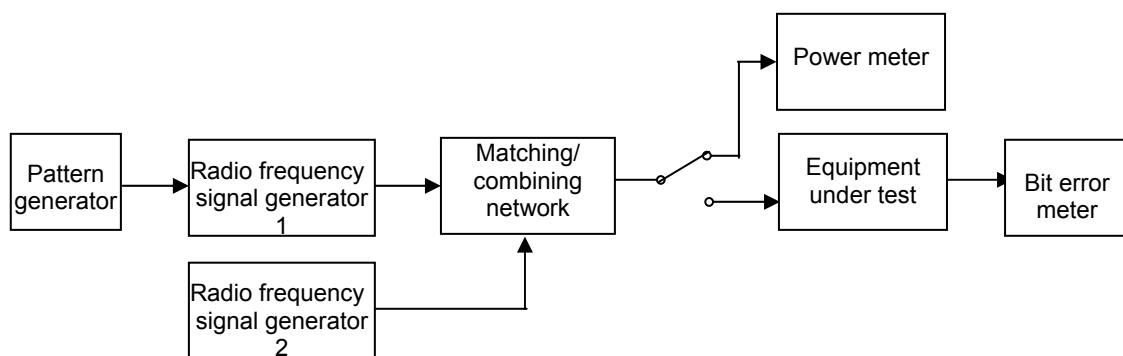

Figure 5.1.2.4 : Measurement system diagram for spurious response immunity

- Radio frequency signal generator 2 does continuous or burst transmission, and is not modulated. Also, the signal level is set at the value which produces $[(\text{specified sensitivity level} + 3 \text{ dB}) + (\text{spurious response immunity specified value})]$ dB μ V.
- The bit error meter accumulates bit sequence from the information channel I (TCH) and measures the error rate for 2556 bits or more.

5.1.2.5. Conducted spurious component:

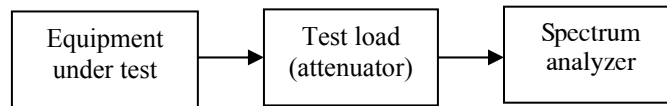

Figure 5.1.2.5: Measurement system diagram for spurious components

Measurement procedures (Measurement diagram is shown in Figure 5.1.2.5)

- Confirm the EUT in standby receiving mode and able to receive test frequency.
- With the spectrum analyzer, confirm spurious components in the specified frequency band.
- Set the spectrum analyzer's central frequency to the frequency checked above, and measure the level of that spurious components.

5.1.2.6. Cabinet radiation

Set the equipment under test to the test frequency, put in reception state, and use the same measurement methods as section 5.1.1.9.

5.1.2.7. Carrier sensing (slot transmission conditions)

a. Equipment conditions:

- The overall operating characteristics test equipment has a function that assign any communication physical slot to the equipment under test in access timing. Also, it provides a slot timing signal to the pattern generator and radio-frequency signal generator.
- The radio-frequency signal generator supplies a signal modulated by the signal from the pattern generator to the overall operating characteristics test equipment-side transmission slot of the communication carrier assigned by the overall operating characteristics test equipment. The overall operating characteristics test equipment and equipment under test are set up while considering the required C/I etc. so that call originating and terminating procedure can be performed.
- The overall operating characteristics test equipment transmits carriers of the level specified in measurement procedures in all communications carriers, except for one certain frequency.

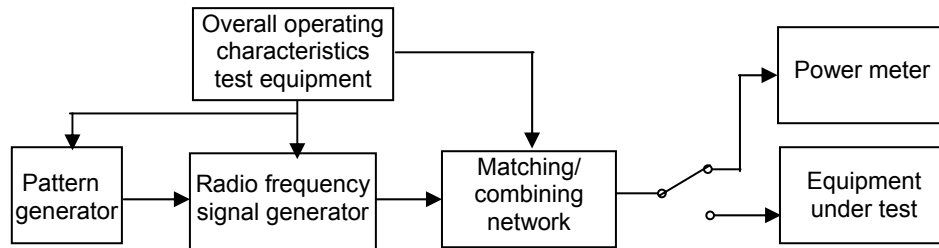

Figure 5.1.2.7: Measurement diagram for carrier sensing

b. Measurement procedures (Measurement diagram is shown in Figure 5.1.2.7)

- Using the overall operating characteristics test equipment, the carrier level is set to $45 \text{ dB}\mu\text{V}$, and progress a call processing sequence with PS under test using a signal of a higher level than this, and it confirms that the communications phase is established at the aforementioned certain frequency.
- Then, transmit a $45 \text{ dB}\mu\text{V}$ signal of the timing specified in section 4.1.10 at the aforementioned certain frequency synchronized to the overall operating characteristics test equipment by the radio-frequency signal generator. It confirms that the communications phase is not established even if the calling operation is performed from PS under test.

5.1.2.8. Received signal strength indicator accuracy

a. Method by area information and standby zone holding function

Measurement procedures (Measurement diagram is shown in Figure 5.1.2.8a)

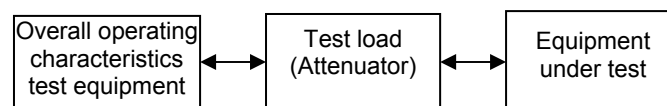

Figure 5.1.2.8 a: Measurement Diagram for Received signal strength indicator accuracy (Method by area information and standby zone holding function)

- Step 1: Set the standby zone holding level of the overall operating characteristics test equipment to the appointed value, and set the standby zone selection level sufficiently higher than that value. Activate the equipment under test under sufficient high input level.
- Step 2: Confirm that the equipment under test has performed location registration. (Operate if manual operation is required.)
- Step 3: After setting the input level from the overall operating characteristics test equipment to the equipment under test at 7 dB (upper allowance + 1 dB) lower than the aforementioned appointed value, confirm the equipment under test

displays the out-of-service-area or does not progress the control sequence even if the outgoing call procedure is performed.

- Step 4: Change the paging area number of the overall operating characteristics test equipment, and after sufficiently increasing the input level to the equipment under test, confirm that the equipment under test performs location registration.

- Step 5: After setting the input level from the overall operating characteristics test equipment to the equipment under test at 7 dB (| lower allowance - 1 dB |) higher than the appointed value, confirm the equipment under test displays the in-service-area or does progress the control sequence and the communication phase is established with the outgoing call procedure.

- Step 6: If necessary, set the standby zone holding level to another value, and repeat steps 1-5.

b. Method by which reception level value is displayed on display or provided display equipment:

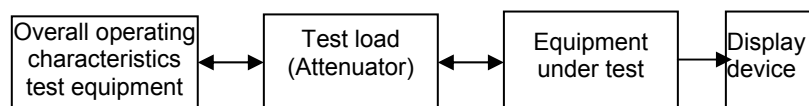

Figure 5.1.2.8 b: Measurement Diagram for Received signal strength indicator accuracy (Method by which reception level value is displayed on display or provided display equipment)

Measurement procedures (Measurement diagram is shown in Figure 5.1.2.8b):

- Step 1: Equipment under test is set in standby state.

- Step 2: Progress the outgoing call or incoming call control sequence between the overall operating characteristics test equipment and the equipment under test, and establish the communications phase.

- Step 3: The input level from the overall operating characteristics test equipment to the equipment under test is set to the value required in measurement, and the display of the display equipment or the equipment under test is read out as the measured value.

- Step 4: If necessary, the input level to the equipment under test is set to another value, and Steps 2-3 are repeated.

- Step 5: Absolutely accuracy is calculated from the measured value of Step 3.

5.1.2.9. Bit error rate floor characteristics

Measure with the similar procedure to 5.1.2.1 sensitivity. However, the signal level is the bit error rate floor characteristics specified value, and the number of bits transmitted is at least 2556×10^6 .

5.2. Measurement methods in case of no measurement terminal

In equipments where there is no antenna measurement terminal and no data input/output terminal, a loop-back path should be able to form between voice CODEC and channel CODEC as shown in Figure 5.2, and by keyboard operations or reception signal commands, it can be set. The loopback should be performed for the information channel I (TCH).

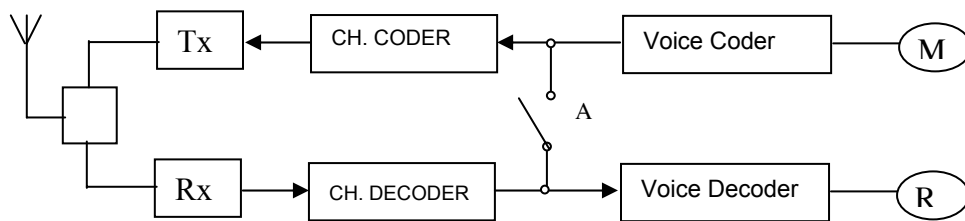

Figure 5.2 Measurement system diagram

5.2.1. Transmission system

5.2.1.1. Frequency error

a. In case of no transmission data input terminal

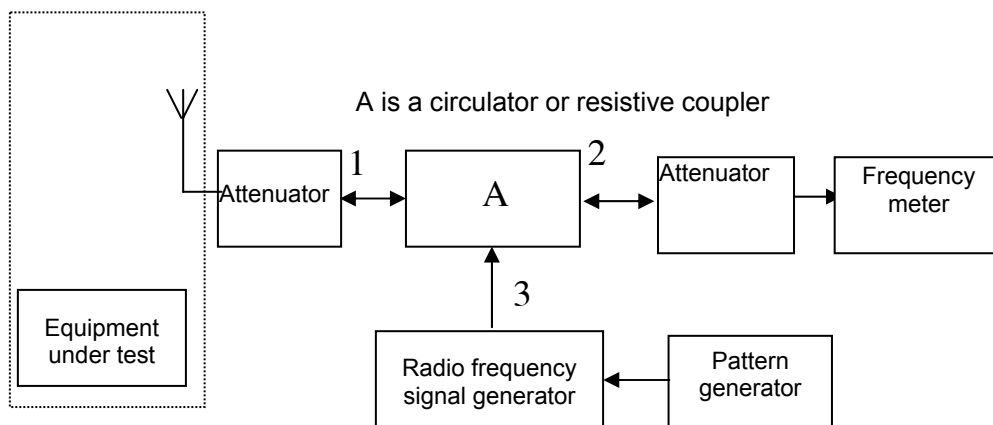

Figure 5.2.1.1: Measurement system diagram in case of no transmission data input terminal

Note:

- The attenuators connected to each terminal of A are set as required for circuit impedance stabilization.
- The measurement system of terminal 2 of A conforms to the case where there are measurement terminals. The system of terminal 3 conforms to the reception system measurement where there are measurement terminals.
- Provides reception input of the degree where almost no errors occur in the reception output of the equipment under test. This level is such that leakage to the terminal 2 of A can be ignored in frequency measurement.
- In the case of a equipment under test that can supply an unmodulated carrier which is the center of the modulated spectrum, the frequency meter can be connected directly to the output of the RFCD.

Measurement procedures (Measurement diagram is shown in Figure 5.2.1.1)

- Set to the loop-back test mode, and transmit at test frequency. If the above unmodulated carrier can be supplied, transmit without modulation.
- Measure the output frequency of the equipment under test in the same way as 5.1.1.1.

b. In case of having data input terminals

The same as (a) is preferable, but the standard coded test signal is supplied from the transmission data input terminal, and the RFCD output or the coupled antenna output can be measured in the same way as when there is a measurement terminal.

Note Both of RFCD and antenna coupling method can be used where using of RFCD or the antenna coupling method are described except otherwise mentioned. However, if no coupling change during the measurement is required, this must be guaranteed. Similarly in the items below.

5.2.1.2. Spurious emission

a. Measurement of effective radiated power

Using the same test site as measurement of cabinet radiation, or an RFCD whose coupling co-efficient is calibrated for each frequency measured using the same model of device at this test site, other measurement conditions are the same as where there is an antenna measurement terminal. The method of providing a loop-back test mode reception signal is the same as 5.2.1.1a. In case of having the data input terminals, it is desirable to use the same manner mentioned above. However, the standard coded test signal can be supplied using urethane carbon impregnated high resistance lines which were confirmed not to affect the peripheral electric field.

b. Presentation of results: Effective radiated power is calculated by dividing the prior measured value by the real value of relative gain of the antenna. In this

case, antenna relative gain is the ratio of the gain which results in the maximum within a 360° 3-dimensional angle of the equipment antenna at the transmission frequency, and the gain in the axial perpendicular direction of the half-wavelength no-loss dipole, and the stated value or the measured value is used for this relative gain.

5.2.1.3. Occupied bandwidth

Similar to 5.2.1.1 but the standard coded test signal is supplied by antenna coupling and loop-back test mode, and other measurement conditions are the same way as 5.1.3. The case where a transmission data input terminal is used also conforms to section 5.2.1.1.

5.2.1.4. Antenna power

Similar to 5.2.1.2.

5.2.1.5. Carrier off time leakage power

Similar to 5.2.1.3 however, confirm that coupling co-efficient variation between measurement frequencies can be ignored.

5.2.1.6. Transient response characteristics of burst transmission

Similar to 5.2.1.3.

5.2.1.7. Modulation accuracy

Similar to 5.2.1.3.

5.2.1.8. Adjacent channel leakage power

Similar to 5.2.1.5.

5.2.1.9. Cabinet radiation

Since the antenna is always connected, it is included in the measurement of spurious emission in 5.2.1.2.

5.2.1.10. Signal transmission rate

Similar to 5.2.1.3.

5.2.1.11. Transmission timing

The equipment under test is installed inside the RFCD, and the RFCD terminal is treated in conformance with an antenna measurement terminal, and measurement should be performed by the same method as the case where there are measurement terminals.

5.2.2 Reception system

5.2.2.1. Sensitivity (test site measurement)

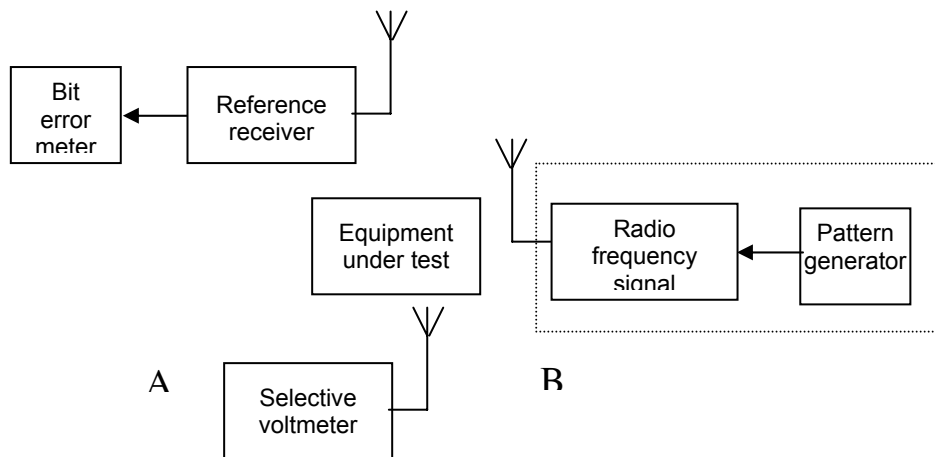

Figure 5.2.2.1.a: Measurement Diagram for Sensitivity (test site measurement)

Note

- Test site conditions are the same as cabinet radiation (section 5.1.1.9).
- A is substituted for the equipment under test, and the electric field strength of that position is measured. The antenna is a half-wavelength dipole antenna.
- The B system is one used for reception system measurement connected to an antenna terminal of the equipment under test where there are measurement terminals.
- The reference receiver receives the waves of the equipment under test, and supplies to the bit error meter that demodulated data that conforms to the signal output to the reception data output terminal of the equipment under test in the case where there are measurement terminals. The waves of the equipment under test can be received nearly error-free, and the reference receiver is to be about 3 m from the equipment under test and 4.2 m from the measurement antenna of B in order not to affect other measurement systems.

Measurement procedures (Measurement diagram is shown in Figure 5.2.2.1.a)

- Set Equipment under test to loop-back test mode, and transmit the test frequency. In case of having the data output terminals, it is desirable to use the same manner mentioned above. However, the measurement may be carried out with the output terminals being connected to the underground bit error meter by a

cord which is hung down just under the equipment. The equipment preassigned surface is to be aligned with the direction of the incoming radio waves.

- Transmit from B, and using A, set the electric field strength of the installation location of the equipment under test to the following value E (dBμV/m).

$$E = \text{Sensitivity specified value (dB}\mu\text{V)} - 20 \log \frac{300}{\pi f \text{ (MHz)}} \text{ (dBm)} - \text{antenna relative gain (dBd)}.$$

- Move on A, set the equipment under test at the location and activate it . The radio waves from the equipment are received by the reference receiver, and measure error rate using the bit error meter.

- Accumulate the bit sequence of the information channel I (TCH) from B, and measure the error rate for 2556 bits or more.

5.2.2.2. Sensitivity (RFCD measurement)

a. When there is no data output terminal

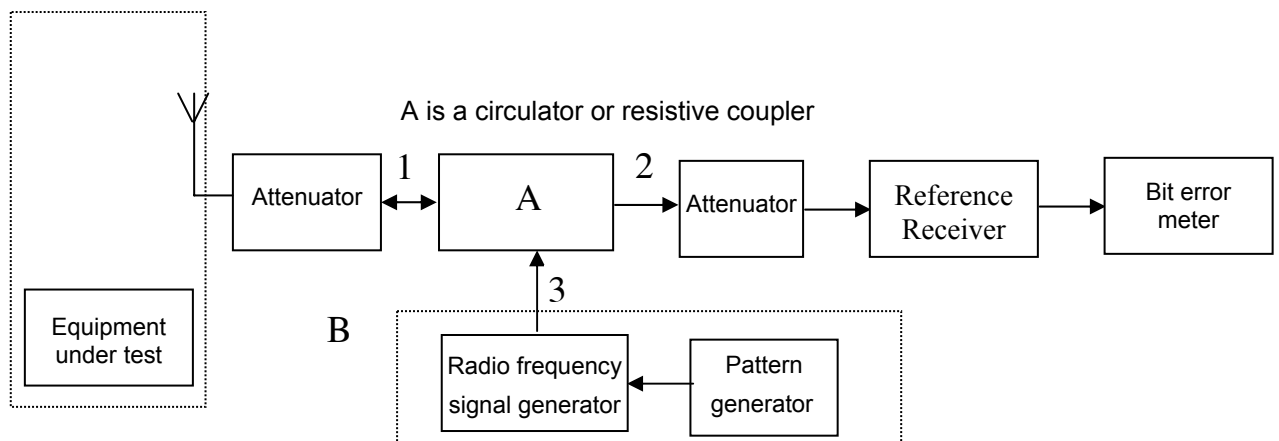

Figure 5.2.2.1.b: Measurement diagram when there is no data output terminal

Note:

- The attenuators connected to each terminal of A are set as required for circuit impedance stabilization and for level adjustment of the two signal systems.
- The measurement system B conforms to the case where there are measurement terminals.
- The reference receiver receives radio-frequency signals of the test frequency, and supplies to the bit error meter the demodulated data that conforms to the signal output to the reception data output terminal of the equipment under test in the case where there are measurement terminals.

- The RFCD has coupling of about 20 dB, and has little effect on the operation of the equipment under test, and is calibrated at the measured frequency using the same equipment in the same test site as in measurement of cabinet radiation (5.1.1.9).
- Input from the equipment under test to the reference receiver is to the degree that there are almost no errors. Output of the radio-frequency signal generator to the equipment under test to be the sensitivity measurement level, and is a level such that there is almost no effect on the aforementioned output to the reference receiver.

Measurement procedures (Measurement diagram is shown in Figure 5.2.2.1.b)

- Set to loop-back test mode, and transmit at test frequency. The equipment under test is aligned to the appointed way of holding and position.
- Conforms to procedure for the case where there are measurement terminals.

b. Where there are reception data output terminals

It is desirable to do the same as (a), however, extending the reception output cord through the RFCD so as not to affect the degree of coupling, and it can be measured in the same way as where there are measurement terminals. In this case as well, the requirement for RFCD should be the same as in (a).

5.2.2.3. Adjacent channel selectivity

In cases where there either are or are not the data output terminals, it should be performed based on the case where there are measurement terminals and section 5.2.2.2.a. or b using an RFCD.

5.2.2.4. Intermodulation performance

Similar to 5.2.2.3.

5.2.2.5. Spurious response immunity

a. Test site measurement:

- The test site has the same conditions as the sensitivity measurement. Electric field setting and loop-back measurement are also the same.
- The undesired signal system is the same as for the measurement terminal. The undesired signal strength is set such that the electric field strength ratio is the specified value of the spurious response immunity.

b. RFCD measurement:

- The RFCD has the same conditions as the sensitivity measurement, and calibrated with the same equipment for each measurement frequency.

- The undesired signal system is the same as for the measurement terminal. The undesired signal strength is set such that the electric field strength ratio is the specified value of spurious response immunity.

5.2.2.6. Conducted spurious components

Since the antenna is always connected, measurement is impossible.

5.2.2.7. Cabinet radiation

Since the antenna is always connected, this measurement includes the radiation of the conducted spurious components. The measurement method is based on transmission cabinet radiation (section 5.1.1.9).

5.2.2.8. Carrier sensing (slot transmission conditions)

a. Test site measurement

- The test site has the same conditions as the sensitivity measurement. Electric field setting is performed in the same way as the input voltage for which measurement is required, instead of sensitivity specification.
- The measurement system structure is a structure where the radio waves pass through the same structure as in the case where there are measurement terminals, and it is measured by the same method.

b. RFCD measurement

- The RFCD has the same conditions as the sensitivity measurement.
- The equipment under test is installed inside the RFCD, and the RFCD terminal is treated in conformance with the antenna measurement terminal, and measurement is performed by the same method as the case where there are measurement terminals.

5.2.2.9. Received signal strength indicator accuracy

a. Test site measurement

- The test site has the same conditions as the sensitivity measurement. Electric field setting is performed in the same way as the input voltage for which measurement is required, instead of sensitivity specification.
- The measurement system structure is a structure where the radio waves pass through the same structure as in the case where there are measurement terminals, and it is measured by the same method. If a display equipment is used, in order to

minimize the effect of its connection on the measurement electric field, it is to be much smaller than the equipment under test, and connection lines other than to the equipment under test are to be unnecessary. Connection should be performed at a short distance, and is affixed where the effect on the equipment under test is small.

b. RFCD measurement

- The RFCD has the same conditions as the sensitivity measurement.
- The equipment under test is installed inside the RFCD, and the RFCD terminal is treated in conformance with an antenna measurement terminal, and measurement is performed by the same method as the case where there are measurement terminals.

If a display equipment is used, in order to minimize the effect of its connection on the measurement electric field, it is to be much smaller than the equipment under test, and connection lines other than to the equipment under test are to be unnecessary. Connection is performed at a short distance, and is affixed where the effect on the equipment under test is small.

5.2.2.10. Bit error rate floor characteristics (test site measurement)

Measure with the similar procedure to 5.2.2.1 sensitivity (test site measurement). However, the signal level is the value of the bit error rate floor characteristics specification, and the number of bits transmitted is at least 2556×10^6 .

5.2.2.11. Bit error rate floor characteristics (RFCD measurement)

Measure with the similar procedure to 5.2.2.2 sensitivity (RFCD measurement). However, the signal level is the value of the bit error rate floor characteristics specification, and the number of bits transmitted is at least 2556×10^6 .

5.3. Method for Other test items

5.3.1. Transmission of Calling Identification Code

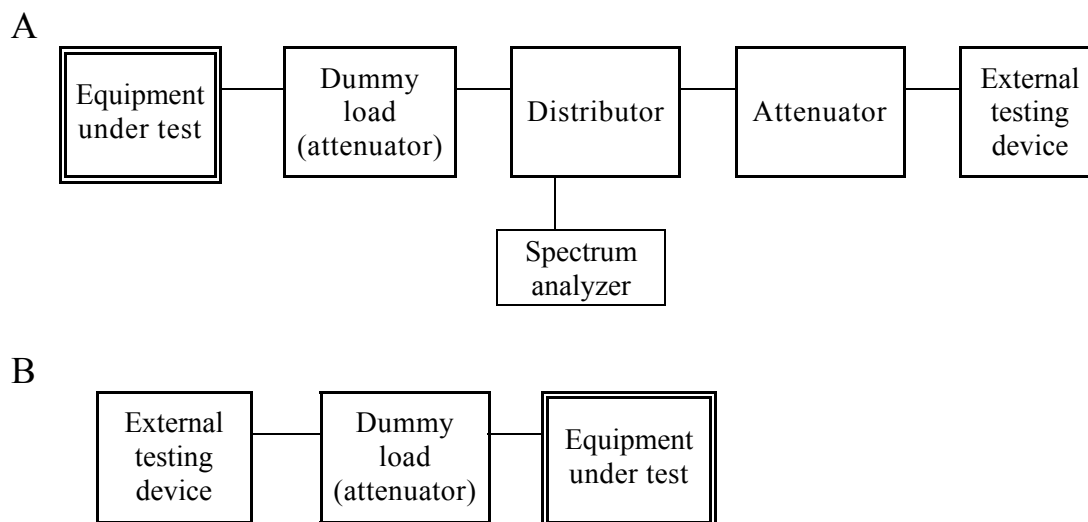

Figure 5.3.1: Measuring System Block Diagram for Transmission of Calling Identification Code

Note: Conditions before testing done

- Attenuation of the attenuator connected to equipment under test shall be about 30 dB.
- In the case of the measuring system diagram A, adjust two attenuators so that the spectrum analyzer can separate signals from the equipment under test and external testing device.
- Set the spectrum analyzer as follows:

Center frequency	: Specific frequency of control channel
Frequency sweep width	: 0 Hz
Resolution bandwidth	: About 300 kHz
Video bandwidth	: About the same as for resolution bandwidth
Y-axis scale	: 10 dB/Div
Input attenuator	: 20 dB
Input reference level	: +10 dBm
- External testing device shall be the device that can be connected to equipment under test and can transmit the prescribed calling code. An opposite equipment communicable with the equipment under test may be used as a substitute.
- Equipment under Test is set as follow:
 - + Place it in a normal operating (standby) state.
 - + Arrange the calling name storage device (ROM) ready for switching from a state having no storage of calling name (or equivalent state) to a state having the storage of call name.

Measuring Operation Procedures (use diagram in figure 5.3.1)

- Call name storage device : By connecting the equipment under test according to the system block diagram A, conduct the following tests:
 - + Make an outgoing or incoming call operation in a state having no call name storage and check that the equipment does not emit radio waves.
 - + Have the call name stored in the equipment.

+ If the decoder is installed with the external testing device, make an outgoing call operation and read with the external testing device the call name decoded.

+ If the decoder is not installed with the external testing device, check that the equipment makes normal transmission under ordinary conditions.

- Identification device: By connecting the equipment under test according to the system block diagram B, conduct the following tests:

+ Transmit the prescribed call name from the external testing device.

+ Check that the equipment under test has received and detected the transmitted call name.

- Presentation of Results

+ Indicate the radio wave transmission and detection with Good or No Good.

+ Indicate the results on the content of call name if necessary.

5.3.2. Test for the Control Channel

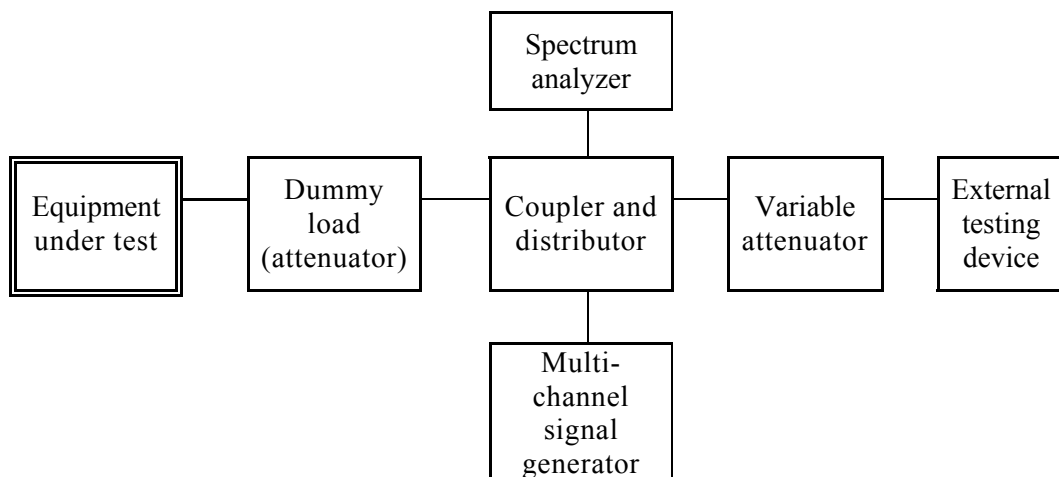

Figure 5.3.2 Measuring System Block Diagram for Control Channel

Note: Conditions before testing done

- The multichannel signal generator generates continuously all carriers without modulation except the specified two frequencies for control (e.g: 1895,150 MHz) and the specified frequency for communication.

- The external testing device has functions of circuit connection with the equipment under test at the specified control channels and confirmation of outgoing/incoming call operations. An opposite equipment communicable with the equipment under test may be used as the substitute of it.

- Set the spectrum analyzer as follows:

Center frequency	: Center frequency of the prescribed bandwidth
Frequency sweep width	: Prescribed bandwidth (e.g : 24 MHz)
Resolution bandwidth	: About 10 kHz
Video bandwidth	: About the same as for resolution bandwidth
Y-axis scale	: 10 dB/Div
Input attenuator	: 20 dB
Input reference level	: +10 dBm

- Equipment under Test is set as follows:
 - + Write the subscriber data to the internal ROM.
 - + Set the receiving state.

Measuring Operation Procedures (use diagram in figure 5.3.2)

- Set the output level of the multichannel signal generator that the input voltage to the equipment under test reaches about 200 μ V.
- Connect the equipment under test with the external testing device at the specified control channels (e.g: 1895,150 MHz), and check with the spectrum analyzer that the radio wave of communication channel is emitted. Check also operations as follows:
 - + Outgoing call operation. (speech, and include on-hook from the equipment under test)
 - + Incoming call operation. (speech, and include on-hook from the external testing device)
- Presentation of Results: Indicate the result with Good or No Good.

ANNEX

ANNEX A (normative): Test Conditions

The temperature conditions and rated voltage supply applied in each test are specified as either nominal or extreme condition as follows,

- Nominal test conditions:

Voltage: 3.6 V Ambient Pressure: 86 ~ 196 kpa

Temperature: 15⁰C ~ 35⁰C Relative Humidity: 5% ~ 75% (no frost)

- Extreme test conditions:

Voltage: max. 3.6 × 1.25 V; min. 3.6 × 0.9 V

(max. 4.5 V; min. 3.24 V)

Temperature: max. 55⁰C ± 1⁰C; min. -10⁰C ± 1⁰C

All tests are contained in the nominal test conditions. The extreme test conditions are determined by the type of the test item. The EUT shall be put in the temperature box for extreme test condition. The measurement of spurious emissions shall be performed in the anechoic chamber which should meet the requirements for shielding loss and wall return loss as shown in Figure A.2.

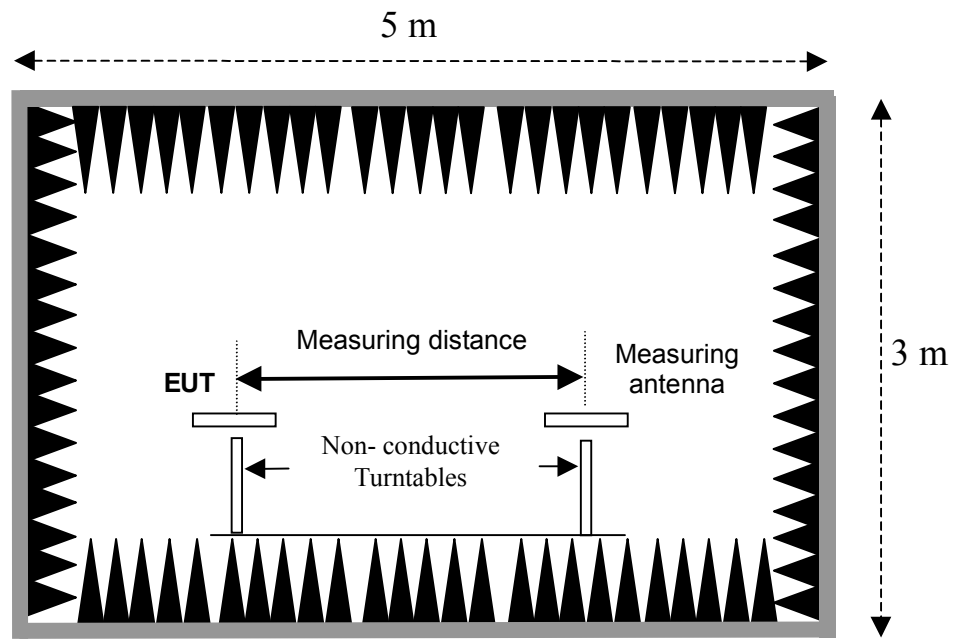

Figure A1. Anechoic chamber used in measurement of spurious emissions

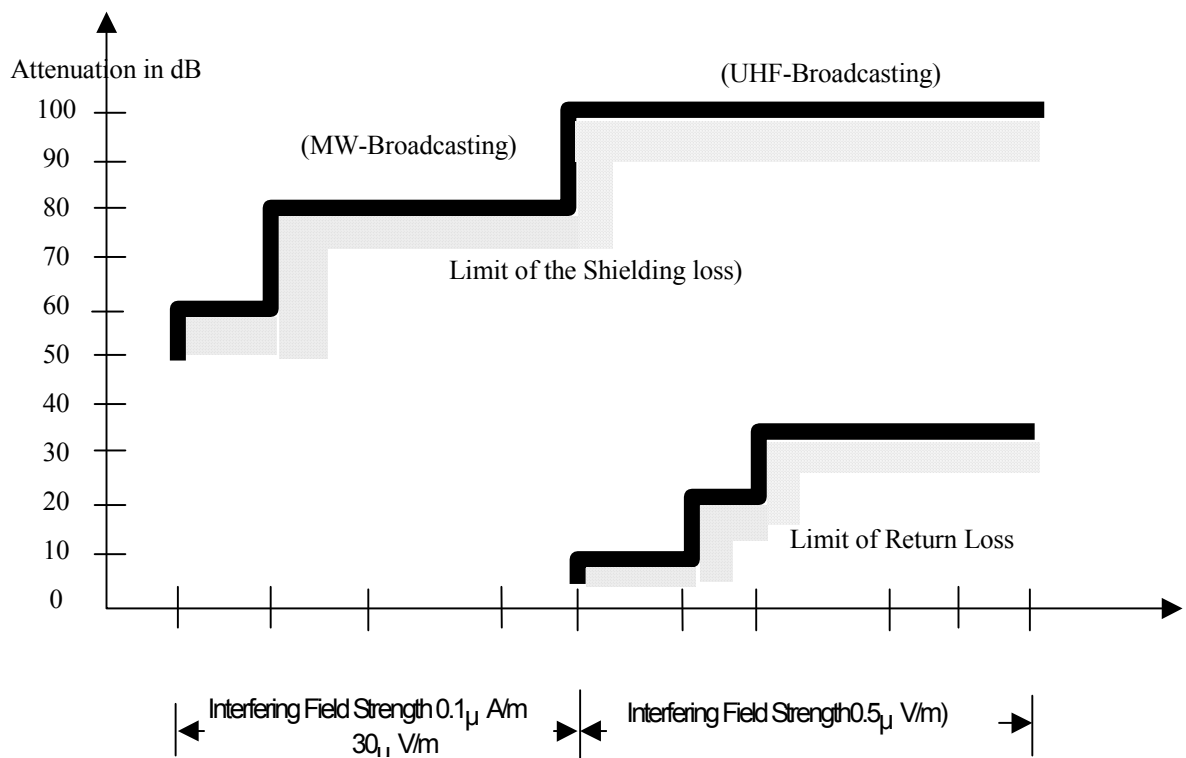

Figure A2. Shield room with absorbers for shielding loss and wall return loss requirements

**ANNEX B (informative): SIGNALLING AND COMMUNICATION
CONTROL METHODS IN PHS SYSTEM**

B.1. Layer 1

Layer 1	RCR STD- 28 V3.2	Remarks
Layer 1 standards	4.2	
Overview	4.2.1	
Definition of functions	4.2.2	
Service characteristics	4.2.3	
Channel types	4.2.4	
Physical slot usage method	4.2.5	
Mapping of logical control channels on the TDMA frame	4.2.6	
Structure of logical control channel	4.2.7	
Communication physical slot designation method	4.2.8	
Slot structure	4.2.9	
Channel coding	4.2.10	
Scramble method	4.2.11	
Standard encryption mechanism	4.2.12	
VOX control	4.2.13	Optional
Specific examples of bit arrangement	4.2.14	
TCH activation procedure and detailed regulations	4.2.15	
Malfunction detection for personal station	4.2.16	
Constraints during automatic response detection	4.2.17	
Constraints when automatically retransmitting	4.2.18	

B.2. Link channel establishment phase

Link channel establishment phase	RCR STD-28 V3.2	Remark
Overview	4.3.1	General Information
General regulations	4.3.2	Heading
Protocol regulations	4.3.2.1	
Format rules	4.3.2.2	
Message format	4.3.2.3	
About definition information	4.3.2.4	
Definition information transmission method	4.3.2.5	
RT-MM version management	4.3.2.6	
Function request method	4.3.2.7	Heading
Usage of the extension LCH protocol type at the link channel establishment phase	4.3.2.7.1	
Conditions for execution of function request sequence	4.3.2.7.2	
Message type list	4.3.3	
Message format	4.3.4	Heading
Channel setup messages	4.3.4.1	Heading
Idle	4.3.4.1.1	
Link channel establishment request	4.3.4.1.2	
Link channel assignment	4.3.4.1.3	
Link channel assignment reject	4.3.4.1.4	
Link channel establishment re-request	4.3.4.1.5	
Broadcasting messages	4.3.4.2	Heading
Radio channel information broadcasting message	4.3.4.2.1	
System information broadcasting message	4.3.4.2.2	
2nd system information broadcasting message	4.3.4.2.3	
3rd system information broadcasting message	4.3.4.2.4	
Option information broadcasting message	4.3.4.2.5	
Paging message	4.3.4.3	
Detailed regulations of PCH paging group	4.3.4.4	

B.3. Service channel establishment phase and Communications phase

B.3.1. Layer 2 standards

Layer 2 standards	RCR STD-28 V3.2	Remarks
Layer 2 standards	4.4.2	Heading
Overview	4.4.2.1	General Information
Range of application of the standard	4.4.2.1.1	
LAPDC overview	4.4.2.1.2	
Format rules	4.4.2.1.3	
Layer 2 frame structure	4.4.2.2	
Relationship between physical slot and frame	4.4.2.2.1	
Elements of SACCH	4.4.2.2.2	
Elements of FACCH	4.4.2.2.3	
Address field	4.4.2.3	
Control field	4.4.2.4	
Information transfer (I) format	4.4.2.4.1	
Supervisory (S) format	4.4.2.4.2	
Unnumbered (U) format	4.4.2.4.3	
Control operation elements	4.4.2.5	
Communication mode	4.4.2.5.1	
P/F (Poll(P)/Final(F) bit	4.4.2.5.2	
Variables and sequence numbers	4.4.2.5.3	
Timers	4.4.2.5.4	
Command and response	4.4.2.6	
Information transfer (I) command	4.4.2.6.1	
Set asynchronous balanced mode (SABM) command	4.4.2.6.2	
Disconnect (DISC) command	4.4.2.6.3	
Receive ready (RR) command / response	4.4.2.6.4	
Receive not ready (RNR) command/response	4.4.2.6.5	
Unnumbered acknowledgment (UA) response	4.4.2.6.6	

Disconnected mode (DM) response	4.4.2.6.7	
Frame reject (FRMR) response	4.4.2.6.8	
Unnumbered information (UI) command	4.4.2.6.9	
Elements for communication between layers	4.4.2.7	
Data link control operations	4.4.2.8	
Procedure classes and operation modes	4.4.2.8.1	
System constants	4.4.2.8.2	
Counters	4.4.2.8.3	
Data link control operation procedures	4.4.2.8.4	
Unacknowledged information transfer procedures	4.4.2.8.4.1	
Multiframe acknowledged operation mode establishing procedures	4.4.2.8.4.2	
Multiframe acknowledged operation mode re-establish	4.4.2.8.4.3	
Multiframe acknowledged operation mode release	4.4.2.8.4.4	
Collision between unnumbered command and response	4.4.2.8.4.5	
Acknowledged information transfer	4.4.2.8.4.6	
Transmission and reception of acknowledgment	4.4.2.8.4.7	
Generation and cancel of reception busy state	4.4.2.8.4.8	
Report and recovery of error state	4.4.2.8.4.9	
Data link supervisory function procedures	4.4.2.8.4.10	

B.3.2. Layer 3 standards

B.3.2.1. General

Layer 3 standards	RCR STD-28 V3.2	Remarks
Layer 3 standards	4.4.3	Heading
Overview	4.4.3.1	General Information

Range of standard	4.4.3.1.1	
Application to interface structure	4.4.3.1.2	
Definition of layer 3 functions	4.4.3.2	
Radio frequency transmission management (RT)	4.4.3.2.1	
Mobility management (MM)	4.4.3.2.2	
Call control (CC)	4.4.3.2.3	
Overview of signal methods		
Layer 3 functions and signal structure	4.4.3.3.1	
Signal format	4.4.3.3.2	
Protocol rules	4.4.3.3.3	
Layer 2 primitives	4.4.3.4	

B.3.2.2. Radio frequency transmission management (RT)

Layer 3 standards - Radio frequency transmission management (RT)	RCR STD-28 V3.2	Remarks
Radio frequency transmission management (RT)	4.4.3.5	
Radio frequency transmission management (RT) state definitions	4.4.3.5.1	
RT state in PS	4.4.3.5.1.1	
RT state in CS	4.4.3.5.1.2	
Definition and contents of message functions	4.4.3.5.2	
Definition information request	4.4.3.5.2.1	
Definition information response	4.4.3.5.2.2	
Condition inquiry	4.4.3.5.2.3	
Condition report	4.4.3.5.2.4	
Encryption control	4.4.3.5.2.5	
Encryption control acknowledge	4.4.3.5.2.6	
Encryption key set	4.4.3.5.2.7	
Function request	4.4.3.5.2.8	
Function request response	4.4.3.5.2.9	
Paging response	4.4.3.5.2.10	
PS Release	4.4.3.5.2.11	

Radio-channel Disconnect	4.4.3.5.2.12	
Radio-channel Disconnect Complete	4.4.3.5.2.13	
TCH Switching Indication	4.4.3.5.2.14	
TCH Switching Request Reject	4.4.3.5.2.15	
TCH Switching Request	4.4.3.5.2.16	
TCH Switching Re-Request	4.4.3.5.2.17	
Transmission Power Control	4.4.3.5.2.18	
VOX Control	4.4.3.5.2.19	
PS-ID notification	4.4.3.5.2.20	
PS Zone information indication	4.4.3.5.2.21	
Message format and information element coding	4.4.3.5.3	
Overview	4.4.3.5.3.1	
Protocol discriminator	4.4.3.5.3.2	
Message type	4.4.3.5.3.3	
Coding regulations and information elements	4.4.3.5.3.4	
Area information	4.4.3.5.3.4.1	
Broadcasting information	4.4.3.5.3.4.2	
Definition information request	4.4.3.5.3.4.3	
Carrier number	4.4.3.5.3.4.4	
Cause	4.4.3.5.3.4.5	
Condition report function	4.4.3.5.3.4.6	
CS-ID	4.4.3.5.3.4.7	
Encryption	4.4.3.5.3.4.8	
Encryption control information	4.4.3.5.3.4.9	
Encryption key set	4.4.3.5.3.4.10	
PS number)	4.4.3.5.3.4.11	
PS-ID	4.4.3.5.3.4.12	
PS-ID Notification control information	4.4.3.5.3.4.13	
Reception level	4.4.3.5.3.4.14	
Report Condition	4.4.3.5.3.4.15	
SCH type	4.4.3.5.3.4.16	
Slot Number	4.4.3.5.3.4.17	
TCH switching	4.4.3.5.3.4.18	

Transmission Power Control	4.3.5.3.4.19	
Transmission Power Control Request	4.4.3.5.3.4.20	
VOX Control	4.3.5.3.4.21	
VOX Function Information	4.4.3.5.3.4.22	
Zone condition report	4.4.3.5.3.4.23	
Zone information indication function	4.4.3.5.3.4.24	
Paging response type	4.4.3.5.3.4.25	
RT supplementary regulations	4.4.3.5.4	

B.3.2.3. Mobility management (MM)

Layer 3 standards Mobility management (MM)	RCR STD-28 V3.2	Remarks
Mobility management (MM)	4.4.3.6	
Mobility management (MM) state definitions	4.4.3.6.1	
MM state in PS	4.4.3.6.1.1	
MM state in CS	4.4.3.6.1.2	
Message function definitions and contents	4.4.3.6.2	
Authentication Request	4.4.3.6.2.1	
Authentication Response	4.4.3.6.2.2	
Function request	4.4.3.6.2.3	
Function request response	4.4.3.6.2.4	
Location Registration Acknowledge	4.4.3.6.2.5	
Location Registration area report	4.4.3.6.2.6	
Location Registration reject	4.4.3.6.2.7	
Location Registration Request	4.4.3.6.2.8	
Message format and information element coding	4.4.3.6.3	
Overview	4.4.3.6.3.1	
Protocol discriminator	4.4.3.6.3.2	
Message type	4.4.3.6.3.3	
Other information elements	4.4.3.6.3.4	
Coding regulations	4.4.3.6.3.4.1	
Active Authentication	4.4.3.6.3.4.2	

Authentication Ciphering Pattern	4.4.3.6.3.4.3	
Authentication Type	4.4.3.6.3.4.4	
Authentication Random Pattern	4.4.3.6.3.4.5	
Cause	4.4.3.6.3.4.6	
Location registration area report	4.4.3.6.3.4.7	
Paging area	4.4.3.6.3.4.8	
Paging group	4.4.3.6.3.4.9	
Example of calculation of Paging Group by paging group number division remainder	4.4.3.6.3.4.9. 1	
PS number	4.4.3.6.3.4.10	
Reception level	4.4.3.6.3.4.11	

B.3.2.4. Call control (CC)

Layer 3 standards - Call control (CC)	RCR STD-28 V3.2	Remarks
Call control (CC)	4.4.3.7	
Call control (CC) state definitions	4.4.3.7.1	
CC state at PS	4.4.3.7.1.1	
CC state at CS	4.4.3.7.1.2	
Functional operation state at PS	4.4.3.7.1.3	
Functional operation state at CS	4.4.3.7.1.4	
Message function definitions and contents	4.4.3.7.2	
CC message overview	4.4.3.7.2.1	
ALERT (ALERTing)	4.4.3.7.2.1.1	
CALL PROC (CALL PROCeeding)	4.4.3.7.2.1.2	
CONN (CONNect)	4.4.3.7.2.1.3	
CONN ACK (CONNectACKnowledge)	4.4.3.7.2.1.4	
DIS (DISConnect)	4.4.3.7.2.1.5	
FAC (FACility)	4.4.3.7.2.1.6	
INFO (INFOrmation)	4.4.3.7.2.1.7	
PROG (PROGress)	4.4.3.7.2.1.8	
REL (RELease)	4.4.3.7.2.1.9	
REL COMP (RELease COMPLete)	4.4.3.7.2.1.10	

SETUP (SETUP)	4.4.3.7.2.1.11	
SETUP ACK (SETUP ACKnowledge)	4.4.3.7.2.1.12	
STAT (STATus)	4.4.3.7.2.1.13	
STAT ENQ(STATus ENQuiry)	4.4.3.7.2.1.14	
NOTIFY (NOTIFY)	4.4.3.7.2.1.15	
Message format and information element coding	4.4.3.7.3	
Overview	4.4.3.7.3.1	
Protocol discriminator	4.4.3.7.3.2	
Call reference	4.4.3.7.3.3	
Message type	4.4.3.7.3.4	
Other information elements	4.4.3.7.3.5	
Coding regulations	4.4.3.7.3.5.1	
Information element identifier code set extension and locking shift procedure	4.4.3.7.3.5.2	
Locking shift	4.4.3.7.3.5.3	
Bearer capability	4.4.3.7.3.5.4	
Call state	4.4.3.7.3.5.5	
Called party number	4.4.3.7.3.5.6	
Called party subaddress	4.4.3.7.3.5.7	
Calling party number	4.4.3.7.3.5.6	
Calling party subaddress	4.4.3.7.3.5.9	
Cause	4.4.3.7.3.5.10	
Facility	4.4.3.7.3.5.11	
Keypad facility	4.4.3.7.3.5.12	
Progress indicator	4.4.3.7.3.5.13	
Sending complete	4.4.3.7.3.5.14	
Signal	4.4.3.7.3.5.15	
Charge notification	4.4.3.7.3.5.16	
Notification indicator	4.4.3.7.3.5.17	
PS identity	4.4.3.7.3.5.18	
High Layer compatibility	4.4.3.7.3.5.19	
Low Layer compatibility	4.4.3.7.3.5.20	
Repeat indicator	4.4.3.7.3.5.21	

Manual call origination indicator	4.4.3.7.3.5.22	
Communication type	4.4.3.7.3.5.23	
Supplementary services	4.4.3.7.4	
Supplementary service types	4.4.3.7.4.1	
PB signal transmission	4.4.3.7.4.1.1	
Hooking signal transmission	4.4.3.7.4.1.2	
State transition tables	4.4.3.7.5	

B.3.2.5. Control sequences - Layer 3 standards

Layer 3- Control sequences	RCR STD-28 V3.2	Remarks
Control sequences	4.4.3.8	General Information
Outgoing call	4.4.3.8.1	Heading
En-block sending	4.4.3.8.1.1	
Overlap sending	4.4.3.8.1.2	
Incoming call	4.4.3.8.2	
Disconnect	4.4.3.8.3	
Location registration	4.4.3.8.4	
Channel switching during communication	4.4.3.8.5	Heading
Channel switching during communication (switching on same CS)	4.4.3.8.5.1	
Channel switching during communication (switching to other CS: PS recalling-type)	4.4.3.8.5.2	
Channel switching during communication (switching to other CS: Recalling-type with PS request)	4.4.3.8.5.3	
Channel switching during communication (switching to other CS: Recalling-type with CS indication)	4.4.3.8.5.4	
Channel switching during communication (switching to other CS: TCH switching-type)	4.4.3.8.5.5	

with PS request)		
Channel switching during communication (switching to other CS: TCH switching-type with CS indication)	4.4.3.8.5.6	
Zone information indication	4.4.3.8.6	
Zone Paging	4.4.3.8.7	

ANNEX C (informative): CONVERSION OF dBm INTO dB μ V

To convert the field strength, with unit of dB μ V/m, to the power density, with unit of dBm/m², we add 115.75 dB to the dBm/m² number to get the corresponding dB μ V/m; This relationship is detected by the free-space impedance of 377 Ohms, and is of the form: $P_D = E^2/Z_0$; Where P_D is the power density, E is the field strength, and Z_0 is the characteristic impedance of the free space (377 Ohms);

At the receiver, the characteristic impedance is 50 Ω , (unless otherwise specified). Whenever there is certain power being received, we can convert it to a corresponding voltage reading through the relationship of $P = V^2/Z$;

ANNEX D (informative): SAMPLE FORM OF ASSESSING TEST REPORTS

D.1. Transmission system

Items	Requirements	Result
Frequency error:	$\leq \pm 3$ ppm	
Transmission spurious: Within band (1893,5 MHz ~ 1919,6 MHz) Outside of band:	≤ 250 nW ≤ 2.5 μ W	
Allowed value for occupied bandwidth :	≤ 288 kHz	
Transmission power	≤ 10 mW +20%, -50%	
Carrier offtime leakage power	≤ 80 nW	
Transient response characteristics of burst transmission - Time - Power	≤ 13.0 μ s ≤ 80 nW	
Modulation accuracy	$\leq 12.5\%$	
Adjacent channel power - $\Delta f = 600$ kHz: - $\Delta f = 900$ kHz:	≤ 800 nW ≤ 250 nW	
Cabinet radiation	≤ 2.5 μ W	
Transmission rate accuracy	$\leq \pm 5$ ppm	
Transmission timing (Figure 4.2) Jitter	± 1 symbol ± 5 ppm $\leq 1/8$ symbol	

D.2. Reception system

Items	Requirements	Result
Sensitivity	≤ 16 dB μ V	
Adjacent channel selectivity $\Delta f = 600$ kHz	≥ 50 dB	

Intermodulation performance	≥ 47 dB	
Spurious response immunity	≥ 47 dB	
Conducted spurious component	≤ 4 nW	
Cabinet radiation f < 1 GHz f > 1 GHz	≤ 4 nW ≤ 20 nW	
Physical slot transmission condition (Figure 4.1) In communication carrier, appropriate corresponding slots are transmitted and used only after sensing the carrier	within 2 seconds	
Receive signal strength indicator accuracy - The reception level detection values (RF level predicted values) for RF input level of 16 dB μ V ÷ 60 dB μ V (dynamic range = 44 dB) - The reception level detection range (RF input level 10dB μ V ÷ 80 dB μ V) and the permitted range of RF level predicted values for reception level detection range	monotonically increasing characteristics, and absolute accuracy is ± 6 dB - shown in Figure 4.4	
BER floor performance	≤ 25 dB μ V	

D.3. Other tests

Items	Requirements	Result (Good/ No good)
Transmission call identification	Good	
Frequency of control carrier	1895.150 MHz	

ANNEX E (informative): SAMPLE FORM OF ASSESSING TECHNICAL DOCUMENTS OR TEST REPORTS

E.1. Signalling and call control

Items	Requirements	Technical documents (Y/N)
Signalling and call control	Comply to Annex B	

E.2. Other requirements

Items	Requirements	Technical documents (Y/N)
Carrier frequencies	Table 4.2	
Multiplex Access/Duplex method	multicarrier TDMA-TDD	
Number of multiplexed circuits for TDMA (use full rate CODEC)	4	
Modulation method	$\pi/4$ QPSK with $\alpha = 0.5$	
Transmission rate	384 kbit/s	
Voice coding rate (use full rate CODEC)	32 kbit/s ADPCM	
Frame length	5 ms	
Antenna gain	≤ 4 dBi	