

TCN 68 – 246: 2006

**TRANSMITTING EQUIPMENT FOR THE ANALOGUE TELEVISION
BROADCASTING SERVICE**

**ELECTROMAGNETIC COMPATIBILITY AND RADIO SPECTRUM
REQUIREMENTS**

CONTENTS

FOREWORD	21
1 SCOPE	22
2 NORMATIVE REFERENCES	22
3 DEFINITIONS, SYMBOLS AND ABBREVIATIONS	22
3.1 Definitions	22
3.2 Abbreviations	24
4 TECHNICAL REQUIREMENTS	24
4.1 Environmental profile	24
4.2 Antenna port measurements	25
4.2.1 Spurious emissions	25
4.2.1.1 Definition	25
4.2.1.2 Method of measurement	25
4.2.1.3 Limit.....	25
4.2.2 Out-of-band emissions	27
4.2.2.1 Definition	27
4.2.2.2 Method of measurement	27
4.2.2.3 Limit.....	27
4.2.3 Transmitter muting during frequency shift	30
4.2.3.1 Definition	30
4.2.3.2 Method of measurement	30
4.2.3.3 Limit.....	30
4.3 Cabinet radiation	30
4.3.1 Definition	30
4.3.2 Method of measurement	30
4.3.3 Limit	31
ANNEX A: (NORMATIVE): GENERAL MEASURING ARRANGEMENTS	33
ANNEX B: (INFORMATIVE) FREQUENCY ASSIGNMENT TABLE FOR TERRESTRIAL TELEVISION SERVICES	35

FOREWORD

The technical standard TCN 68-246: 2006 “**Electromagnetic compatibility and Radio spectrum Matters (ERM); Transmitting equipment for the analogue television broadcasting service**” is based on ETSI EN 302 297 v1.1.1 (2005-01) of European Telecommunications Standards Institute (ETSI).

The technical standard TCN 68-246: 2006 is drafted by Research Institute of Posts and Telecommunications (RIPT) at the proposal of Department of Science & Technology and issued following the Decision No. 27/2006/QD-BBCVT of the Minister of Posts and Telematics dated 25/7/2006.

The technical standard TCN 68-246: 2006 is issued in a bilingual document (Vietnamese version and English version). In cases of interpretation disputes, Vietnamese version is applied.

DEPARTMENT OF SCIENCE & TECHNOLOGY

TRANSMITTING EQUIPMENT FOR THE ANALOGUE TELEVISION BROADCASTING SERVICE

ELECTROMAGNETIC COMPATIBILITY AND RADIO SPECTRUM REQUIREMENTS

*(Issued together with the Decision No. 27/2006/QD-BBCVT dated 25/7/2006
of the Minister of Posts and Telematics)*

1 Scope

The present standard is applied to television transmitter equipment for analogue television broadcasting service, with 8 MHz RF channel bandwidths, operating in the specified frequency bands. These frequencies are currently within the television bands I, III, IV and V.

The present standard is used as one of the basis to type approval and testing of transmitting equipment for the analogue television broadcasting service in electromagnetic compatibility and radio spectrum matters.

2 Normative references

EN 302 297 v1.1.1 (2005-01) "Electromagnetic compatibility and Radio spectrum Matters (ERM); Transmitting equipment for the analogue television broadcasting service; Harmonized EN under article 3.2 of the R&TTE Directive.

3 Definitions, symbols and abbreviations

3.1 Definitions

Antenna port: Port of an apparatus which is designed, in normal operation, to be connected to an antenna.

Analogue television: Television in which picture information is represented by an analogue signal.

NOTE: Sound information can be represented by an analogue and/or digital signal.

Broadcasting service: Radiocommunication service in which the transmissions are intended for direct reception by the general public.

Cabinet radiation: Radiation from an enclosure containing equipment, excluding radiation from connected antennas or cables.

Carrier power: Average power supplied to the antenna port by a transmitter during one radio frequency cycle taken under the condition of no modulation.

Class of emission: Set of characteristics of an emission designated by standard symbols, e.g. type of modulation of the main carrier, modulating signal, type of information to be transmitted, and also, if appropriate, any additional signal characteristics.

dBc: Decibels relative to the unmodulated carrier power of the emission.

NOTE: In the cases which do not have a carrier, for example in some digital modulation schemes where the carrier is not accessible for measurement, the reference level equivalent to dBc is decibels relative to the mean power.

Enclosure port: Physical boundary of the apparatus through which electromagnetic fields may radiate or impinge.

NOTE: In the case of integral antenna equipment, this port is inseparable from the antenna port.

Exclusion band: Band of radio frequencies where no measurements are made.

Harmonic: Component of order greater than 1 of the Fourier series of a periodic quantity.

Harmonic number: Integral number given by the ratio of the frequency of a harmonic to the fundamental frequency.

Intermodulation products: Unwanted frequencies resulting from intermodulation between carriers or harmonics of emission or between any oscillations generated to produce the carrier.

Mean power: Average power supplied to the antenna port by a transmitter during an interval of time sufficiently long compared with the lowest frequency encountered in the modulation taken under normal operating conditions.

NOTE: For analogue television transmissions, the mean power level is defined with a specified video signal modulation. This video signal has to be chosen in such a way that the maximum mean power level (e.g. at the video signal blanking level for PAL) is provided to the antenna transmission line.

Necessary bandwidth: For a given class of emission, the width of the frequency band which is sufficient to ensure the transmission of information at the rate and with the quality required under specified conditions.

Out-of-band emissions: Emission on a frequency or frequencies immediately outside the necessary bandwidth which results from the modulation process, but excluding spurious emissions.

Rated output power: Rated output power is the power that the transmitter or transposer shall deliver at its output under specified conditions of operation.

Reference bandwidth: Bandwidth in which the emission level is specified.

Spurious emissions: Emission on a frequency or frequencies which are outside the necessary bandwidth and the level of which may be reduced without affecting the corresponding transmission of information Spurious emissions include harmonic emissions, parasitic emissions, intermodulation products and frequency conversion products but exclude out-of-band emissions.

Television transmitter: Equipment with a video input and one or more audio inputs and a combined vision and sound radio frequency output.

Unwanted emissions: Consist of spurious emissions and out-of-band emissions.

3.2 Abbreviations

DQPSK	Differential Quadrature Phase Shift Keying
EMC	Electro Magnetic Compatibility
EUT	Equipment Under Test
FM	Frequency Modulation
LV	Low Voltage
NICAM	Near Instantaneous Companded Audio Multiplex
PAL	Phase Alternating on the Line
R&TTE	Radio and Telecommunications Terminal Equipment
RF	Radio Frequency
TV	TeleVision
VSB	Vestigial Side Band
W	Watt

4 Technical requirements

4.1 Environmental profile

The environmental profile for operation of the equipment shall be declared by the supplier. The equipment shall comply with all the technical requirements of the present document at all times when operating within the boundary limits of the required operational environmental profile.

4.2 Antenna port measurements

4.2.1 Spurious emissions

4.2.1.1 Definition

Emission on a frequency or frequencies which are outside the necessary bandwidth and the level of which may be reduced without affecting the corresponding transmission of information. Spurious emissions include harmonic emissions, parasitic emissions, intermodulation products and frequency conversion products but exclude out of band emissions.

4.2.1.2 Method of measurement

- Test environment: the normal operating environment, as declared by the equipment manufacturer.

- Test frequencies:

- The lowest operating frequency of the EUT;
- The highest operating frequency of the EUT;
- A frequency mid-way between frequencies above.

- Test arrangement (see figure A.1):

- Connect the Test Signal Generator to the EUT;
- Connect the EUT to the Test Load, via the Coupling Device;
- Connect the Spectrum Analyser to the Coupling Device.

The test signal shall be as defined in clause A.1.3.1.

- Procedure:

- Set the Test Signal Generator to deliver a test signal;
- Operate the EUT at each of the test frequencies;
- Measure the results on the Spectrum Analyser.

4.2.1.3 Limit

Spurious emissions shall not exceed the values set out in table 4.1, shown additionally in figure 4.1 for the frequency range 9 kHz to 4.5 GHz.

Table 4.1: Spurious emission limits for analogue television broadcast transmitters

Mean power of the transmitter	Limits mean power absolute levels (dBm) or relative levels (dBc) below the power supplied to the antenna port in the reference bandwidth (see annex A)
$P < 9 \text{ dBW}$	-36 dBm
$9 \text{ dBW} < P < 29 \text{ dBW}$	75 dBc
$29 \text{ dBW} < P < 39 \text{ dBW}$	-16 dBm
$39 \text{ dBW} < P < 50 \text{ dBW}$	85 dBc
$50 \text{ dBW} < P$	-5 dBm

NOTE: Within the band 108 MHz to 137 MHz the limits above shall apply without exceeding the absolute limit of $25 \mu\text{W}$ (-16 dBm).

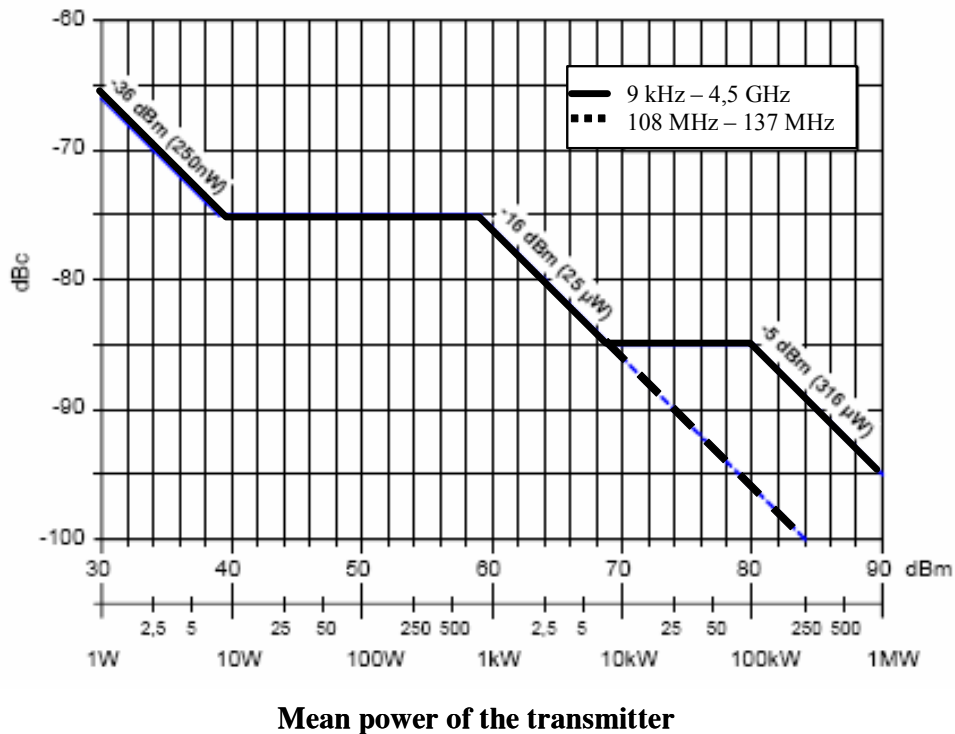

Figure 4.1: Spurious emission limits for analogue television broadcast transmitters

4.2.2 Out-of-band emissions

4.2.2.1 Definition

Emission on a frequency or frequencies immediately outside the necessary bandwidth which results from the modulation process, but excludes spurious emissions.

4.2.2.2 Method of measurement

- Test environment: the normal operating environment, as declared by the equipment manufacturer.

- Test frequencies:

- The lowest operating frequency of the EUT;
- The highest operating frequency of the EUT;
- A frequency mid-way between frequencies above.

- Test arrangement (see figure A.1):

- Connect the Test Signal Generator to the EUT;
- Connect the EUT to the Test Load, via the Coupling Device;
- Connect the Spectrum Analyser to the Coupling Device.

The test signal shall be as defined in clause A.1.3.2.

- Procedure:

- Set the Test Signal Generator to deliver a test signal;
- Operate the EUT at each of the test frequencies;
- Measure the results on the Spectrum Analyser.

4.2.2.3 Limit

Out-of-band emissions shall not exceed the values set out in tables 4.2, 4.3, and spectrum limit mask is shown in figure 4.2.

Each graph is drawn to represent the spectrum limits for transmitters in the output power range 39 dBW to 50 dBW.

For 8 MHz analogue television, the Out-Of-Band domain extends from ± 4 MHz (i.e. $\pm 0.5 \times 8$ MHz) to ± 20 MHz (i.e. $\pm 2.5 \times 8$ MHz).

A 50 kHz measurement bandwidth is used. The 0 dB reference level corresponds to the peak sync power. The highest mean power for negative modulation is assumed to be 2.5 dB below peak sync power.

Table 4.2 provides break points corresponding to the graph shown in figure 4.2, for 8 MHz analogue television, negative modulation, 0.75 MHz VSB.

Table 4.2: Break points for 8 MHz analogue television, negative modulation, 0.75 MHz VSB

Frequency relative to the vision carrier frequency (MHz)	8MHz channel, Frequency relative to the channel centre frequency (MHz)	Relative level in 50 kHz reference bandwidth (dB)
-17.25	-20	-90.5
-9.25	-12	-65.5
-6.5	-9.25	-56
-6	-8.75	-36
-3	-5.75	-36
-1.25	-4	-36
-0.75	-3.5	-16
-0.18	-2.93	-16
0	-2.75	0
0.18	-2.57	-16
5	2.25	-16
5.435	2.685	-10
6.565	3.815	-10
6.802	4.052	-25
6.94	4.19	-50
13	10.25	-56
14.75	12	-65.5
22.75	20	-90.5

Table 4.3 provides end point values to be used in conjunction with table 4.2 and figure 4.2, applicable to a range of transmitter output powers, for 8 MHz analogue television, negative modulation.

Table 4.3: End point values for 8 MHz analogue television, negative modulation

End point value (see note) (50 kHz measurement bandwidth) (dB)	Power range (dBW)	Corresponding spurious level (in 100 kHz measurement bandwidth)
$80.5 - (P - 9)$	$P \leq 9$	-36 dBm
-80.5	$9 < P \leq 29$	75 dBc
$-80.5 - (P - 29)$	$29 < P \leq 39$	-16 dBm
-90.5	$39 < P \leq 50$	85 dBc
$-90.5 - (P - 50)$	$50 < P$	-5 dBm

NOTE: The end point value is subject to an upper limit of -65.5 dB.

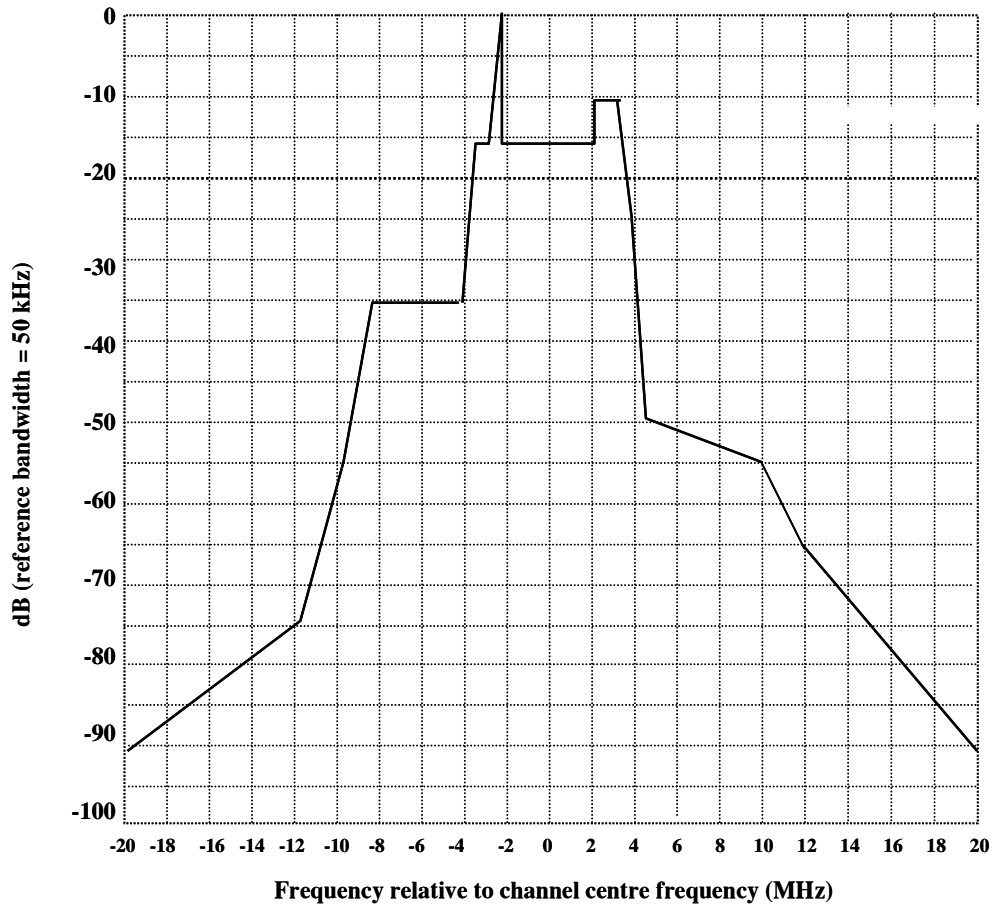

Figure 4.2: Spectrum limit mask for 8 MHz analogue television, negative modulation (for $P = 39$ dBW to 50 dBW)

4.2.3 Transmitter muting during frequency shift

4.2.3.1 Definition

The suppression of emissions during the retuning of transmitters, or the loss of carrier frequency control.

4.2.3.2 Method of measurement

- Test environment: the normal operating environment, as declared by the equipment manufacturer.

- Test frequencies: present frequency to desired frequency.

- Test arrangement (see figure A.1):

- Connect the EUT to the Test Load, via the Coupling Device;

- Connect the Spectrum Analyser to the Coupling Device.

NOTE: Test Signal Generator and Voltage measuring equipment are not required for this test.

- Procedure:

- Operate the EUT at the present frequency;

- Initiate frequency change;

- Measure the results on the Spectrum Analyser.

4.2.3.3 Limit

The Muting shall be as defined in table 4.1 and additionally shown in figure 4.1 (spurious emission limit).

4.3 Cabinet radiation

4.3.1 Definition

Emissions from the equipment, radiated from the enclosure port, other than those present at the antenna port.

4.3.2 Method of measurement

- Test environment: the normal operating environment, as declared by the equipment manufacturer.

- Test frequencies:

- The lowest operating frequency of the EUT;

- The highest operating frequency of the EUT;

- A frequency mid-way between frequencies above.

- Test arrangement: (see figure A.2)

- Connect the Test Signal Generator to the EUT;

- Connect the EUT to the Test Load;
- Connect the Spectrum Analyser to the measuring antenna.
- Procedure:

The test method shall be in accordance with EN 55022 (TCN 68-193:2000), unless physical size is a restriction, in which case the test method shall be in accordance with EN 55011:

- Measurements shall be made outside exclusion band (see table 4.4) of the necessary bandwidth of the transmission.

- Measurements shall be made in the operational mode producing the largest emission in the frequency band being investigated consistent with normal applications.

- The equipment shall be configured in a manner which is representative of a normal/typical operation, where practical.

- An attempt shall be made to maximize the detected radiated emission, e.g. by moving the cables of the equipment.

- The configuration and mode of operation during measurements shall be precisely noted in the test report.

- RF input/output ports shall be correctly terminated.

- The tests shall be carried out at a point within the specified normal operating environmental range and at the rated supply voltage for the equipment.

4.3.3 Limit

Radiated emissions shall not exceed the values set out in table 4.4, shown additionally in figure 4.3, for the frequency range 30 MHz to 4.5 GHz.

This test shall be performed at a distance of 10 m, where feasible. When size and/or power requirements necessitate testing in a manufacturing facility, other distances may be used and it is necessary to care some notes:

- The measurements can be carried out at other distances. In that case limits are modified according to the relation:

$$L(x) = L(10m) + 20 \log (10/x) \text{ where } x = \text{distance in meter (m)}$$

- Care should be taken if measuring at test distances below 10 m as this may be in the near field.

- In cases of dispute the measurement distance of 10 m shall take precedence.

Table 4.4: Cabinet radiation limits

Quasi-peak limits (dB μ V/m) at 10 m (see notes 1 and 2)	Frequency range
$30 \leq 60 + 10 \log_{10}(P_0/2000) \leq 70$	30 MHz ÷ 230 MHz
$37 \leq 67 + 10 \log_{10}(P_0/2000) \leq 77$	230 MHz ÷ 2.5 GHz

NOTE 1: P_0 = RF output power in W.
 NOTE 2: The exclusion band for the transmitter extends from $f_c - 24$ MHz to $f_c + 24$ MHz, where f_c is the channel centre frequency in MHz.

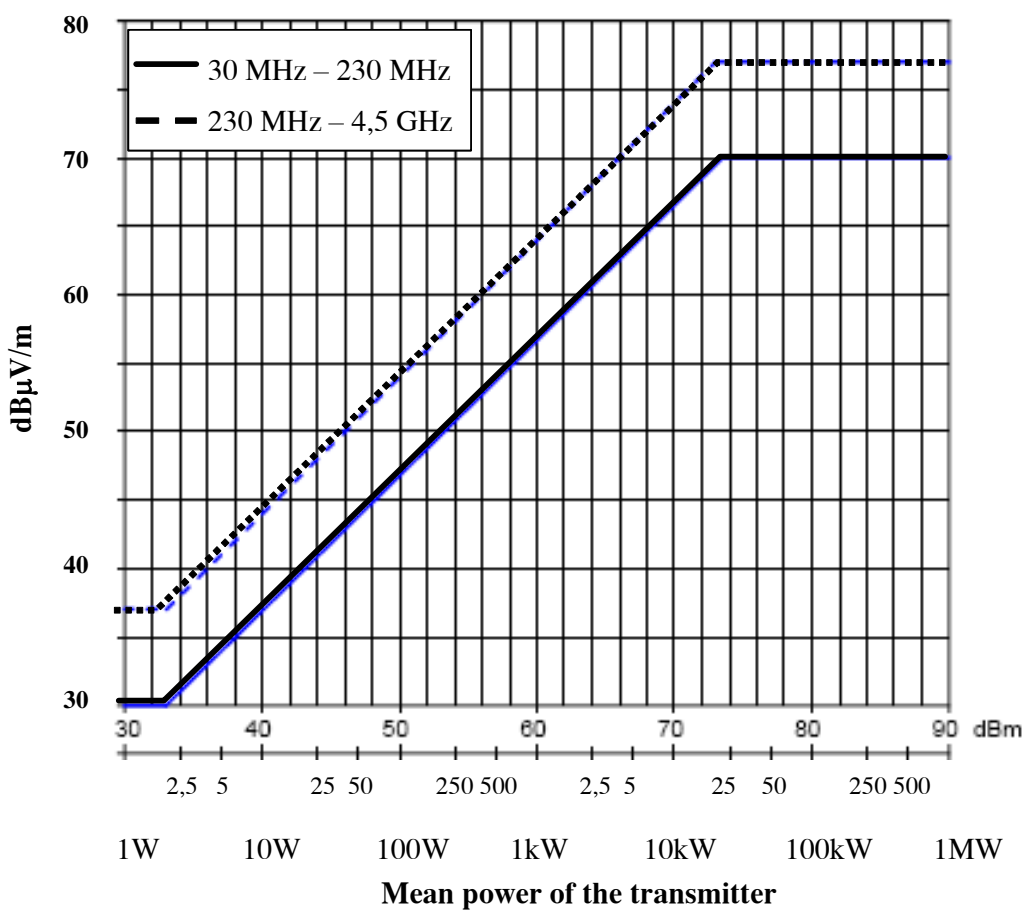

Figure 4.3: Cabinet radiation limits for analogue television transmitter

ANNEX A: GENERAL MEASURING ARRANGEMENTS (NORMATIVE)

A.1 Testing arrangements for antenna port measurements

For test arrangements for unwanted emissions see figure A.1.

A.1.1 Spurious and out-of-band emissions

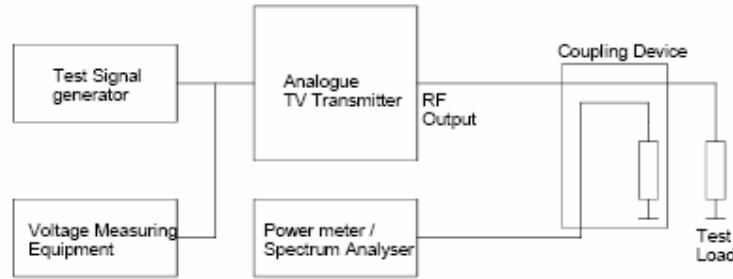

Figure A.1: Testing arrangement for unwanted emissions

A.1.2 Test frequency range

Limits on unwanted emissions for radio equipments are considered to be applicable to the range 9 kHz to 300 GHz.

However, for practical measurement purposes, the frequency range of spurious emissions may be restricted. As guidance for practical purposes, the following measurement parameters in table A.1 are recommended.

Table A.1: Test frequency range

Transmitter fundamental frequency range	Unwanted emission frequency measurement range	
	Lower frequency	Upper frequency
47 MHz ÷ 862 MHz	9 kHz	4.5 GHz

The following reference bandwidths are to be used:

For spurious emissions:

- 1 kHz between 9 kHz and 150 kHz;
- 10 kHz between 150 kHz and 30 MHz;
- 100 kHz between 30 MHz and 1 GHz;
- 1 MHz above 1 GHz.

For out-of-band emissions:

- 50 kHz.

A.1.3 Test modulating signal

A.1.3.1 Spurious emissions

The Vision carrier shall be amplitude modulated with composite sync pulses with black level, the Sound carrier shall be frequency modulated with a 1 kHz sinusoidal signal at a level to cause a frequency deviation of 50 kHz.

A.1.3.2 Out-of-band emissions

The Vision carrier shall be amplitude modulated with composite sync pulses and a 350 mV luminance bar with a superimposed, full amplitude, signal swept in frequency between 0.2 MHz and 5.2 MHz (B,G) and 5.5 MHz (I), the Sound carrier shall be frequency modulated with a 1 kHz sinusoidal signal at a level to cause a frequency deviation of 50 kHz.

A.2 Testing arrangements for enclosure port (radiated emissions) measurements

Testing arrangements for enclosure port (radiated emissions) are shown in the figure A.2.

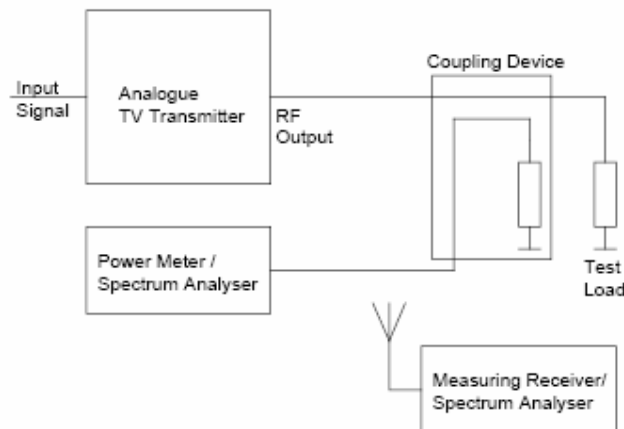

Figure A.2: Testing arrangement for cabinet radiation

**ANNEX B: FREQUENCY ASSIGNMENT TABLE FOR
TERRETRIAL TELEVISION SERVICES**

(from the Decision No. 192/2003/QĐ-BBCVT dated 22/12/2003)

(INFORMATIVE)

Band	Channel	Channel Limits (MHz)	Vision frequency (MHz)	Sound frequency (MHz)	Note
II	3	76 - 84	77.25	83.75	Only for Tam Dao transmitting station
III	6	174 - 182	175.25	181.75	
	7	182 - 190	183.25	189.75	
	8	190 - 198	191.25	197.75	
	9	198 - 206	199.25	205.75	
	10	206 - 214	207.25	213.75	
	11	214 - 222	215.25	221.75	
	12	222 - 230	223.25	229.75	
IV	21	470 - 478	471.25	477.75	
	22	478 - 486	479.25	485.75	
	23	486 - 494	487.25	493.75	
	24	494 - 502	495.25	501.75	
	25	502 - 510	503.25	509.75	
	26	510 - 518	511.25	517.75	
	27	518 - 526	519.25	525.75	
	28	526 - 534	527.25	533.75	
	29	534 - 542	535.25	541.75	
	30	542 - 550	543.25	549.75	
	31	550 - 558	551.25	557.75	
	32	558 - 566	559.25	565.75	
	33	566 - 574	567.25	573.75	
34	574 - 582	575.25	581.75		

Band	Channel	Channel Limits (MHz)	Vision frequency (MHz)	Sound frequency (MHz)	Note
V	35	582 - 590	583.25	589.75	
	36	590 - 598	591.25	597.75	
	37	598 - 606	599.25	605.75	
	38	606 - 614	607.25	613.75	
	39	614 - 622	615.25	621.75	
	40	622 - 630	623.25	629.75	
	41	630 - 638	631.25	637.75	
	42	638 - 646	639.25	645.75	
	43	646 - 654	647.25	653.75	
	44	654 - 662	655.25	661.75	
	45	662 - 670	663.25	669.75	
	46	670 - 678	671.25	677.75	
	47	678 - 686	679.25	685.75	
	48	686 - 694	687.25	693.75	
	49	694 - 702	695.25	701.75	
	50	702 - 710	703.25	709.75	
	51	710 - 718	711.25	717.75	
	52	718 - 726	719.25	725.75	
	53	726 - 734	727.25	733.75	
	54	734 - 742	735.25	741.75	
	55	742 - 750	743.25	749.75	
	56	750 - 758	751.25	757.75	
	57	758 - 766	759.25	765.75	
	58	766 - 774	767.25	773.75	
	59	774 - 782	775.25	781.75	
	60	782 - 790	783.25	789.75	
	61	790 - 798	791.25	797.75	
	62	798 - 806	799.25	805.75	